



Yamanashi Now: From Iconic Relic to Urban Incubator

Citation

Guo, Wentao. 2022. Yamanashi Now: From Iconic Relic to Urban Incubator. Master's thesis, Harvard Graduate School of Design.

Permanent link

<https://nrs.harvard.edu/URN-3:HUL.INSTREPOS:37373975>

Terms of Use

This article was downloaded from Harvard University's DASH repository, and is made available under the terms and conditions applicable to Other Posted Material, as set forth at <http://nrs.harvard.edu/urn-3:HUL.InstRepos:dash.current.terms-of-use#LAA>

Share Your Story

The Harvard community has made this article openly available.
Please share how this access benefits you. [Submit a story](#).

[Accessibility](#)

Yamanashi Now: From Iconic Relic to Urban Incubation

A Thesis Submitted to the Department of Architecture
Harvard University Graduate School of Design, by

Wentao Guo

In Partial Fulfillment of the Requirements for the Degree of
[Master of Architecture]

December 2022

(Month and Year Thesis Submitted)

“The author hereby grants Harvard University permission to reproduce and distribute copies of this thesis, in whole or in part, for educational purposes.”

(signature)



[Student Name]

(signature)



[Thesis Advisor Name]

Abstract

In 1966, Kenzo Tange devised a powerful apparatus of disseminating mass media, Yamanashi Broadcasting and Press Center. A concrete innovation and an urban fragment, the Yamanashi Building applied the joint-core system that could fulfill his imagination of an indefinitely intensified production environment at an urban center. Nonetheless, Tange could neither foresee social challenges, such as a sinking economy and aging society, nor could he realize the fragile nature of mass media. His efforts of self-containing a monochrome production service inside a monolithic structure led the Yamanashi Building, like many other concrete urban renewal buildings during the postwar era, to quickly derail from its original metabolism projection .

This thesis attempts to adapt the existing concrete structure to reengage with the contemporary social and urban context. The re-hybridization of the production-centric program, through reintroducing a lifestyle of production, living, and consumption, reinstates the visibility and dynamics of production. Aiming to reactivate the building vertically, the proposal challenges the construction of servant space, decentralizing the structure through liberating circulation and redefining the boundary of public and private. By occupying the surface of structure, the intervention creates a transparency that contrasts with the historical image at multiple scales, attracting a population of diverse ages. At an urban scale, the adaptation physically and programmatically mediates the institutional scale urban renewal and adjacent neighborhood, reinvigorating vacant blocks. Once an iconic urban concrete relic, the Yamanashi Building becomes an urban incubator that celebrates the history of production with a contemporary fashion.



Yamanashi Broadcasting and Press Centre is at the center of Kofu city, a second-tier city 100 km west of Tokyo. The city center has been declined since the bubble economy, leaving many parcels vacant or parking lots.

Similar to many other medieval Japanese cities, Kofu was historically built around Kofu Castle, which registers local political and economy power. Craftsman would gather around the castle to provide daily service.

Since 1868, the beginning of Meiji Restoration, Kofu has been modernized and westernized with multiple single factory structure that condenses efficient production and replaces the original urban fabric. The production started to be manipulated with gender reference and machine replaced individual skill and knowledge.

In the postwar era, the city was transformed by infrastructural and institutional scale architecture each occupying a single plot after WWII, during which Japan was experiencing an unprecedented economy and technology boom.

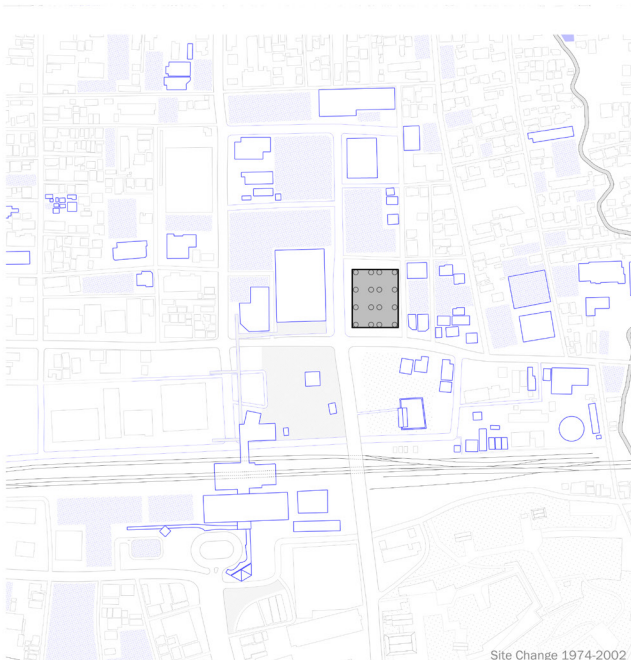
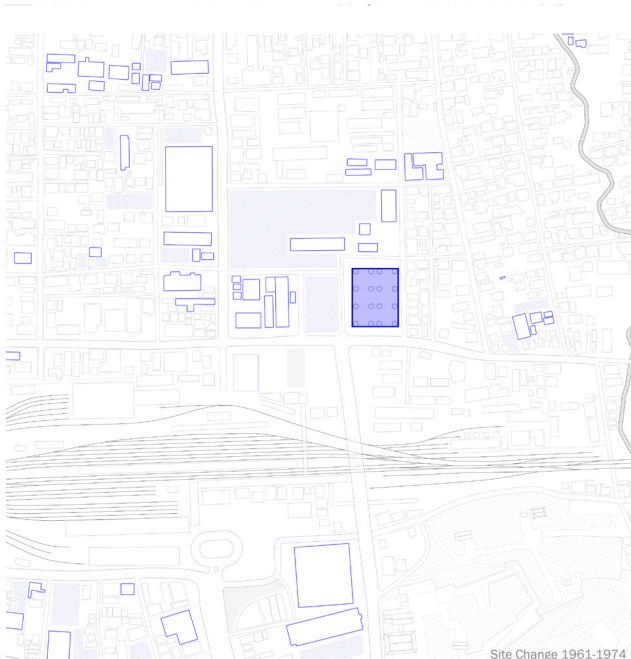

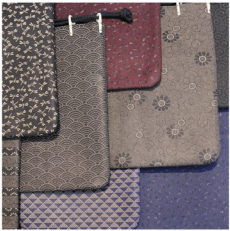

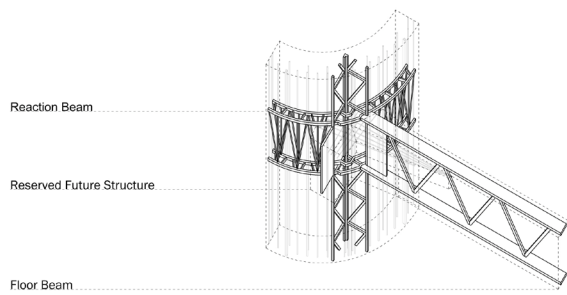
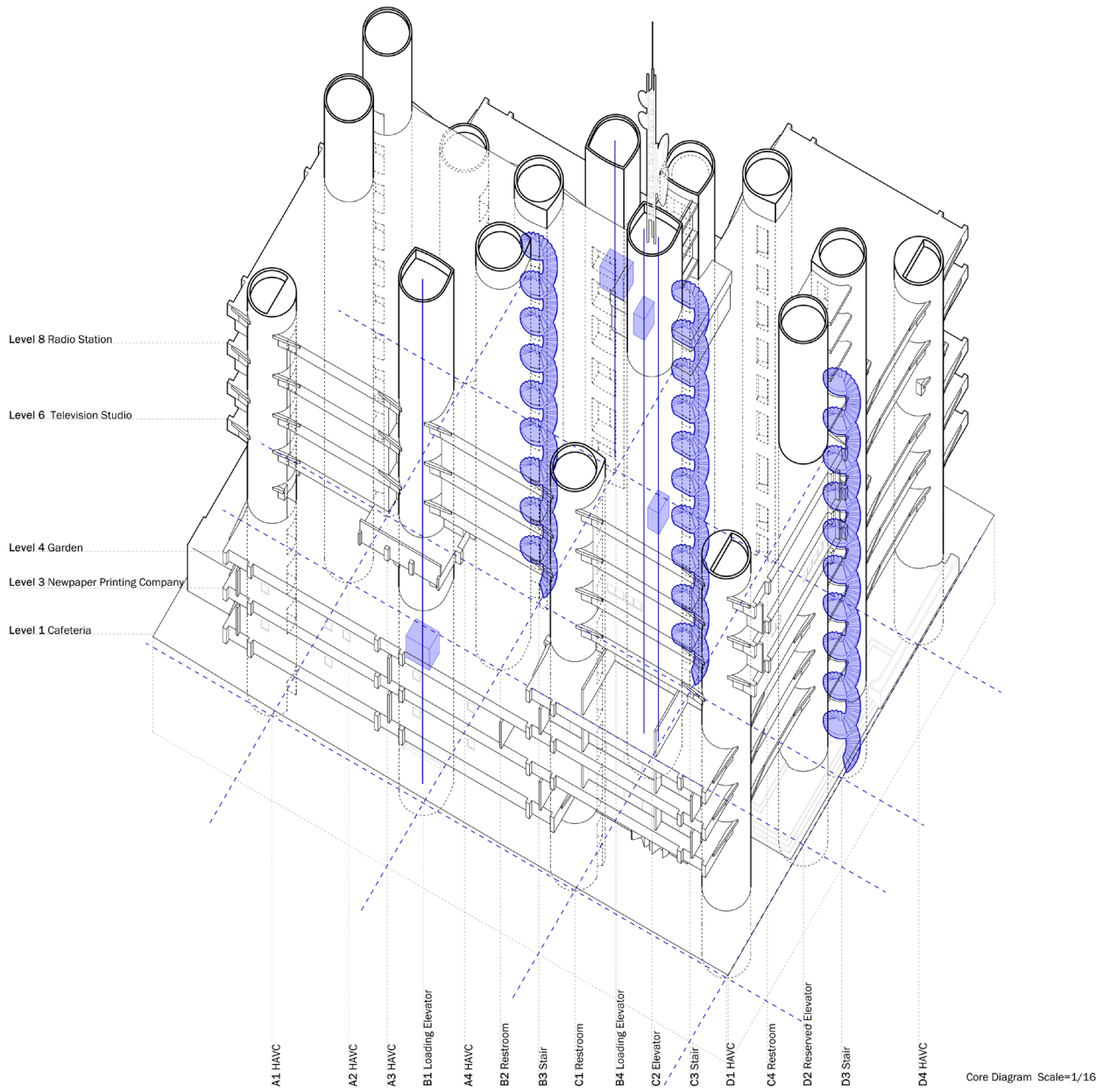

Detail Structure Diagram Sale=1/8

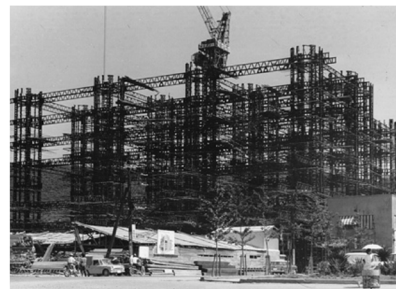

Construction Photo in 1964

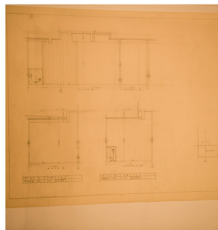
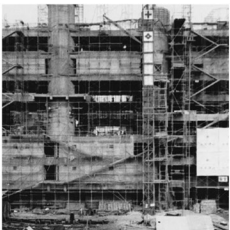
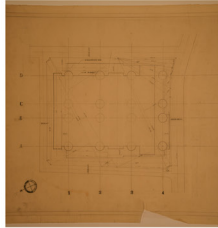
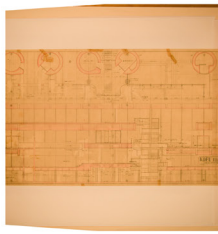
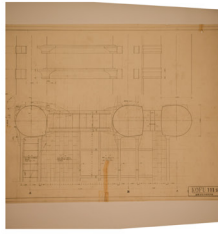

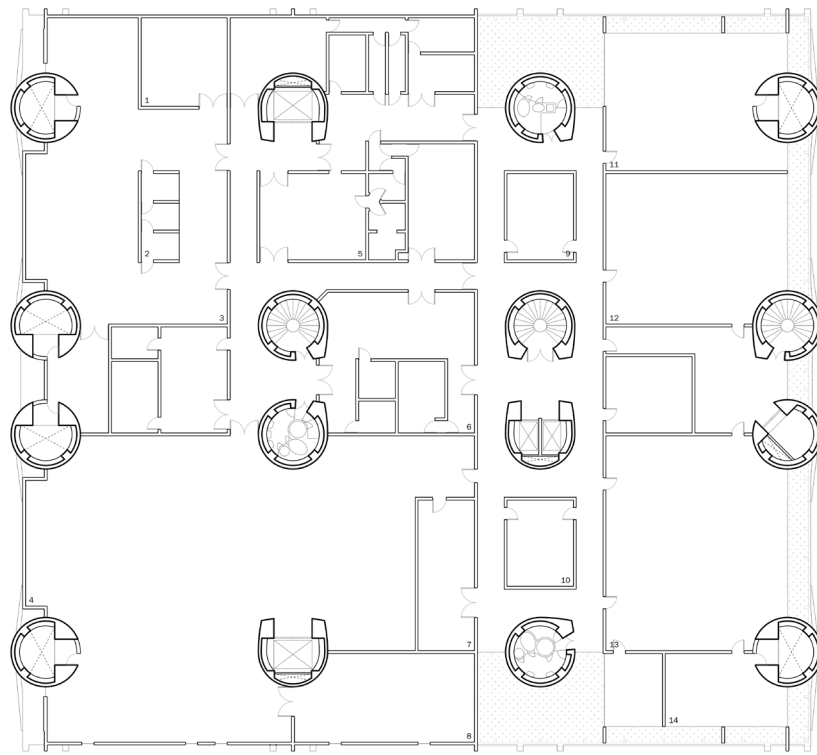

- 1 Correction Room
- 2 Meal Spray Booth
- 3 Printing Plate Room
- 4 Typology Department
- 5 News Retouch Room
- 6 Gallery Camera Room
- 7 Correction Room
- 8 Manotype Room
- 9 Meeting Room
- 10 Guest Correction Room
- 11 Photopresenting Room
- 12 Production Planning Room
- 13 Editing Department
- 14 Archive

Level 3 Plan Scale=1/8

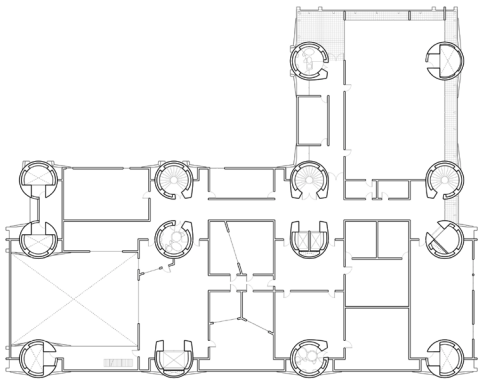

Level 7 Radio Studio Scale=1/24

Tange's Yamanashi Broadcasting and Press Centre was constructed during such a boom. Mass Media Technologies become an ever powerful dissemination apparatus and an ever efficient production space is required to produce a maximized political and social impact in a single building.

Tange envisions a 3 dimensional lattice system that grows both horizontally and vertically. The idea of the vertical core becoming servant spaces that registers not only circulation, but in his mind, a communication system.

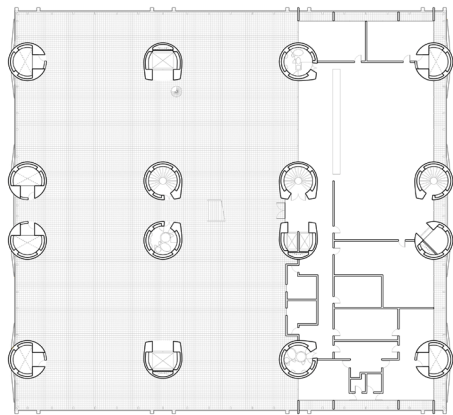

Level 4 Plan Office Scale=1/24

Therefore, the construction of the building was heavily dominated by the 3 dimensional lattice structure. The structure was constructed by 16 vertical columns with openings supported by horizontal beams on a grid of 15 by 17 meter. The structure becomes a 3 dimensional opaque circulation system while production space takes the center space in each bay.

Tange imaged a hybrid of programs vertically, in which cafeteria and public programs are on the ground floor while 3 mass media companies, respectively newspaper printing, television broadcasting and radio center, locates at 3rd, 6th and 8th floor due to requirement of noise insulation.

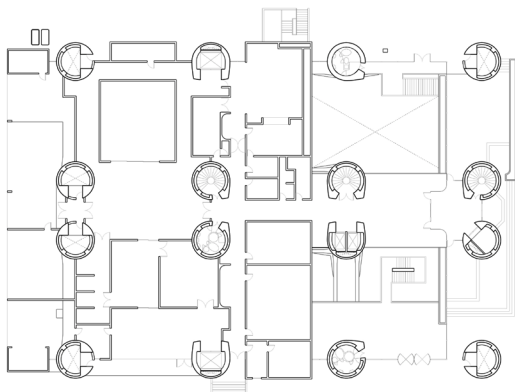

Level 1 Plan Rentspace Scale=1/24

A fragment of an urban scale development, the structure would be named as a joint-core system that worked with a 3 dimensional urban system that the metabolism and other modern futurists would imagine, cars at different levels, structure being infinitely expanded; production space being infinitely intensified.

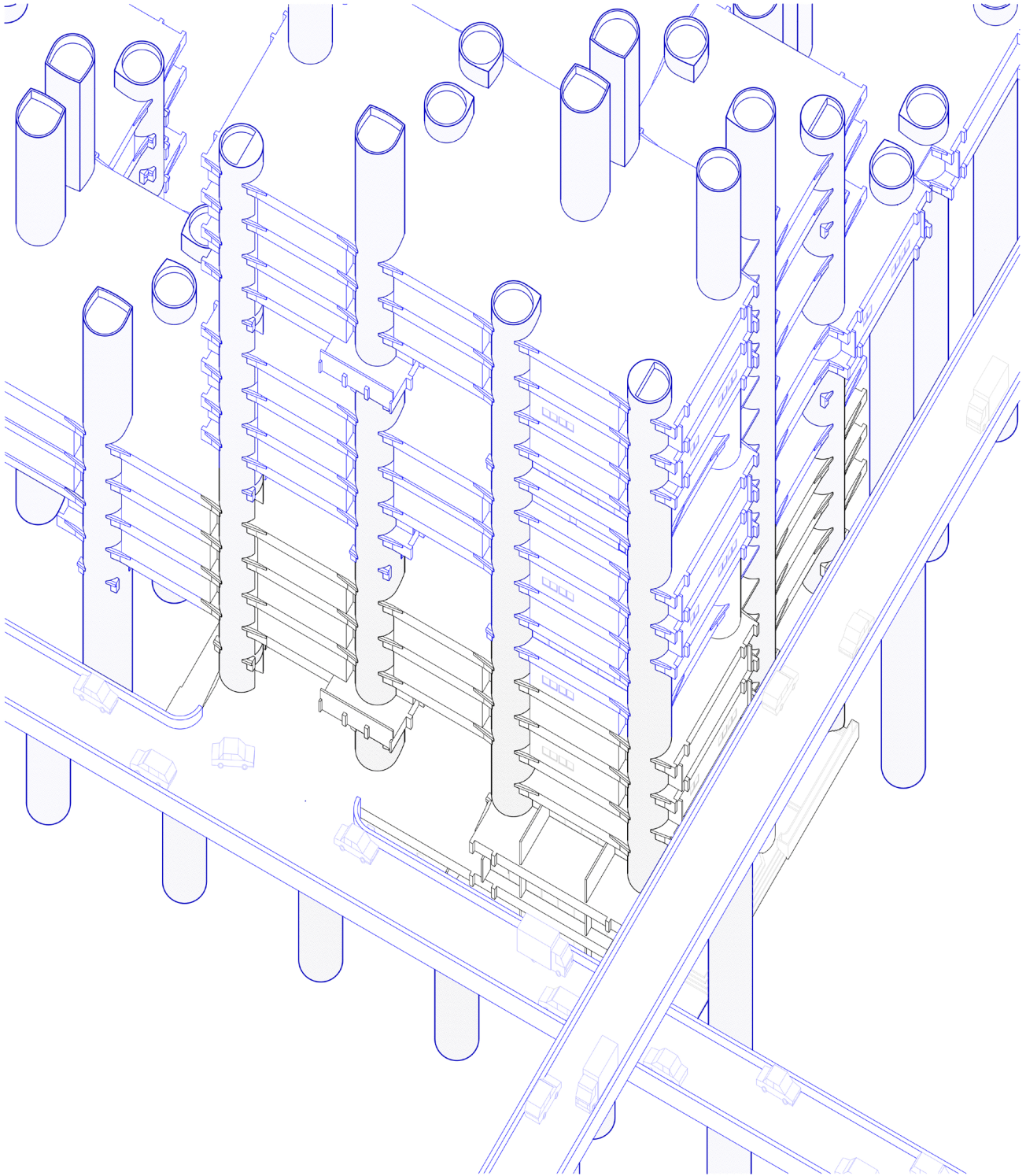

Kenzo Tange's Possible Imagination

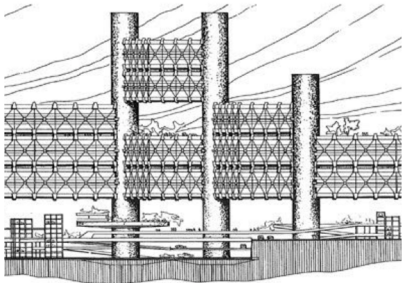

Joint-Core System Proposal by Arata Isozaki

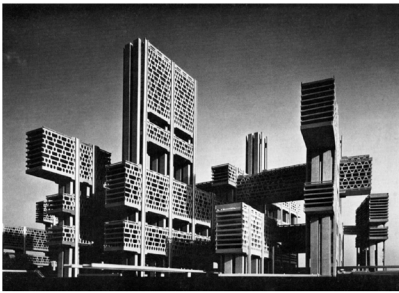

Dentsu Tsukiji Development

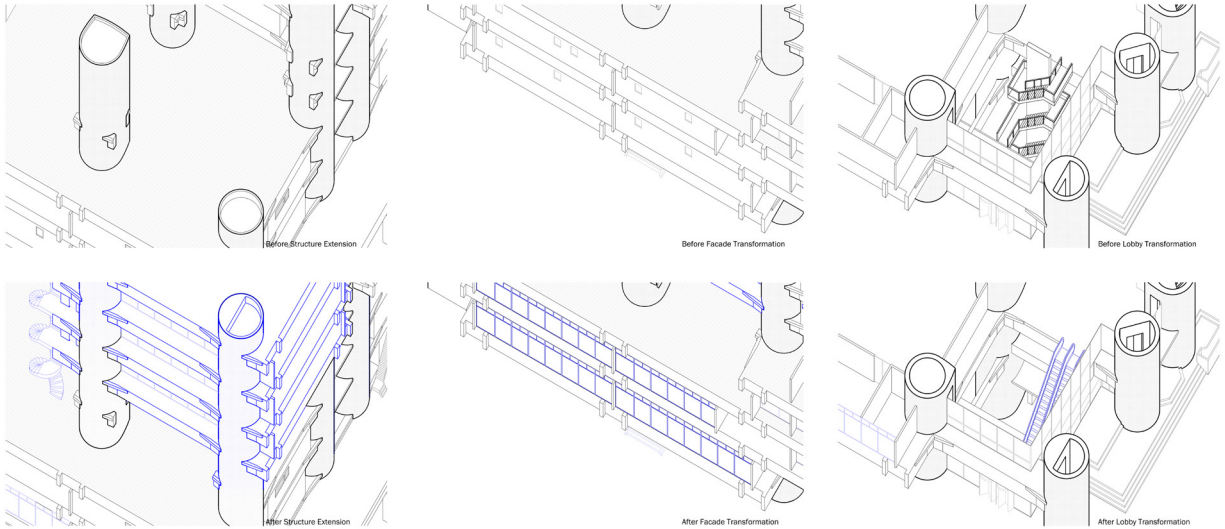

However, Tange was unable to foresee the bubble economy and multiple social problems including aging population and low birth rate. The building was left an urban concrete giant in between the institutional scale buildings and local neighborhoods.

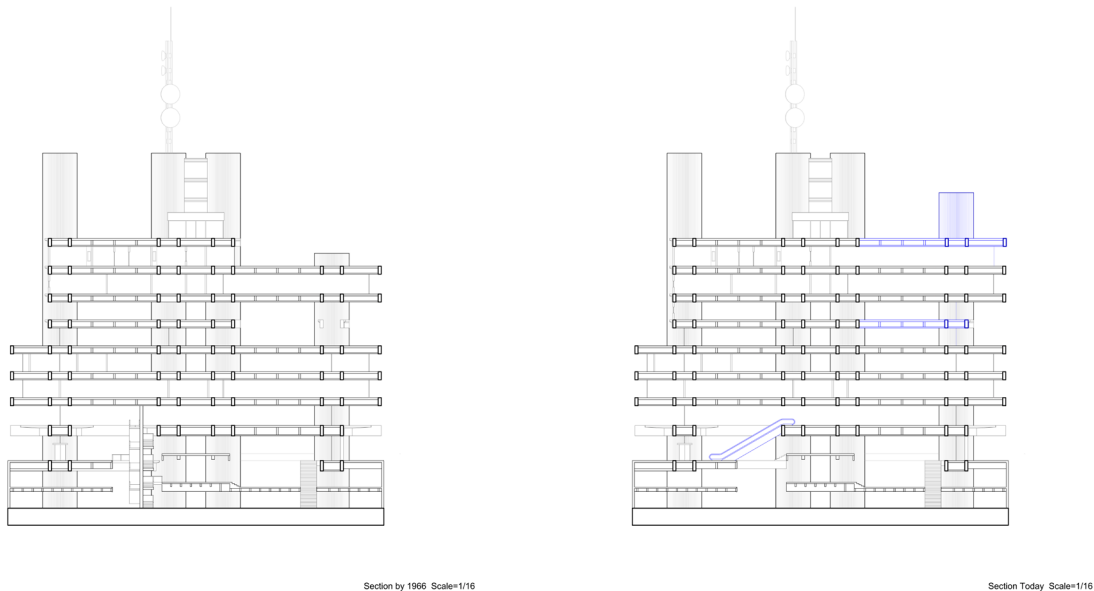

Even though the building has undergone 6 updates in the past 50 years, including extension of the lattice structure, replacement of concrete wall to glazing facade, reconfiguration of parti walls, and installation of escalator in the lobby. But with all of the social crisis above, the architecture has been monochromed into a single production apparatus with generic offices replacing designed mass media studios and other specific programs. At the same time, surrounding neighborhoods has been gradually replaced by vacant parking lots.

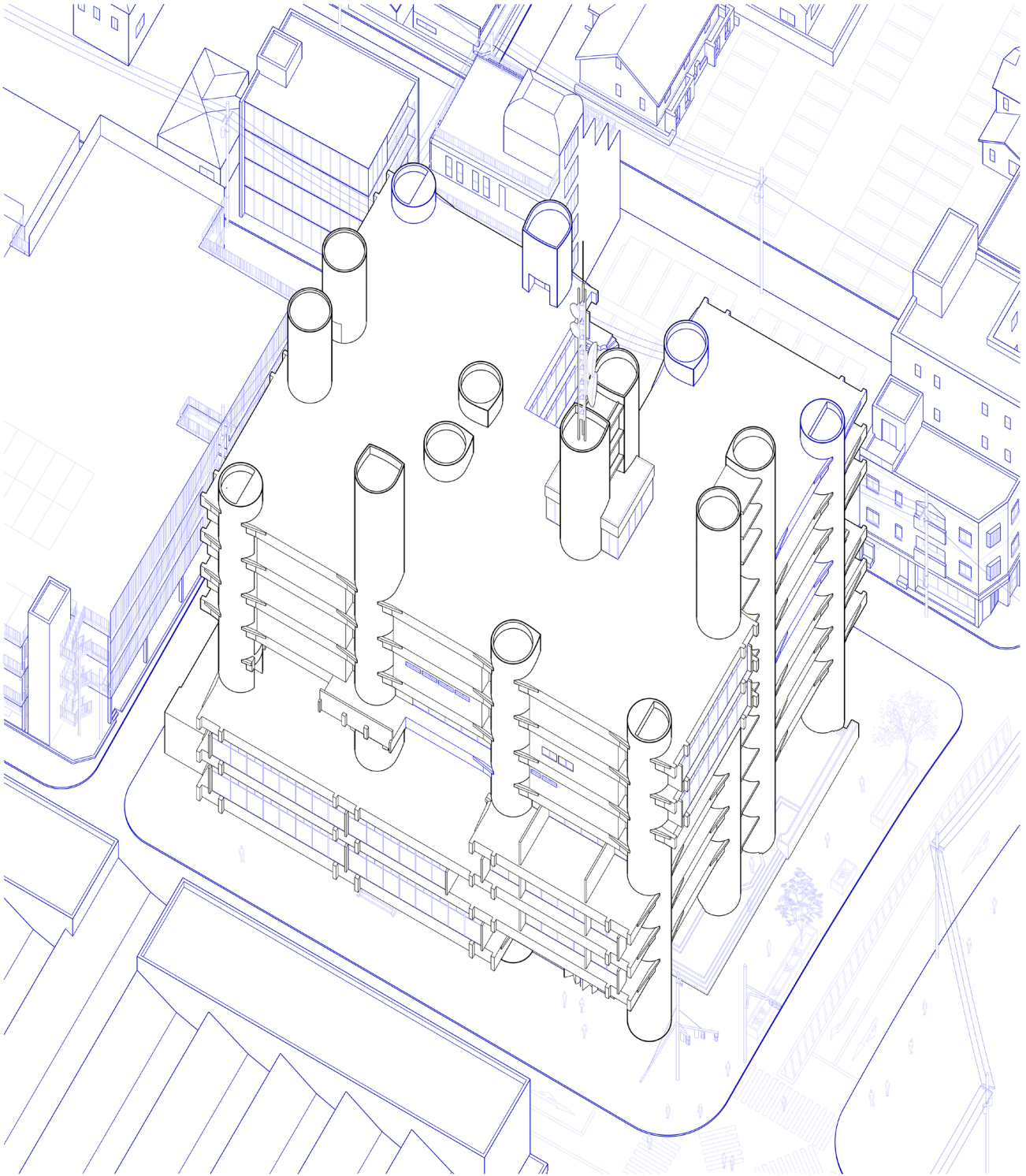

Yamanashi Building Today



Yamanashi Building by 1966



Yamanashi Building by 1974



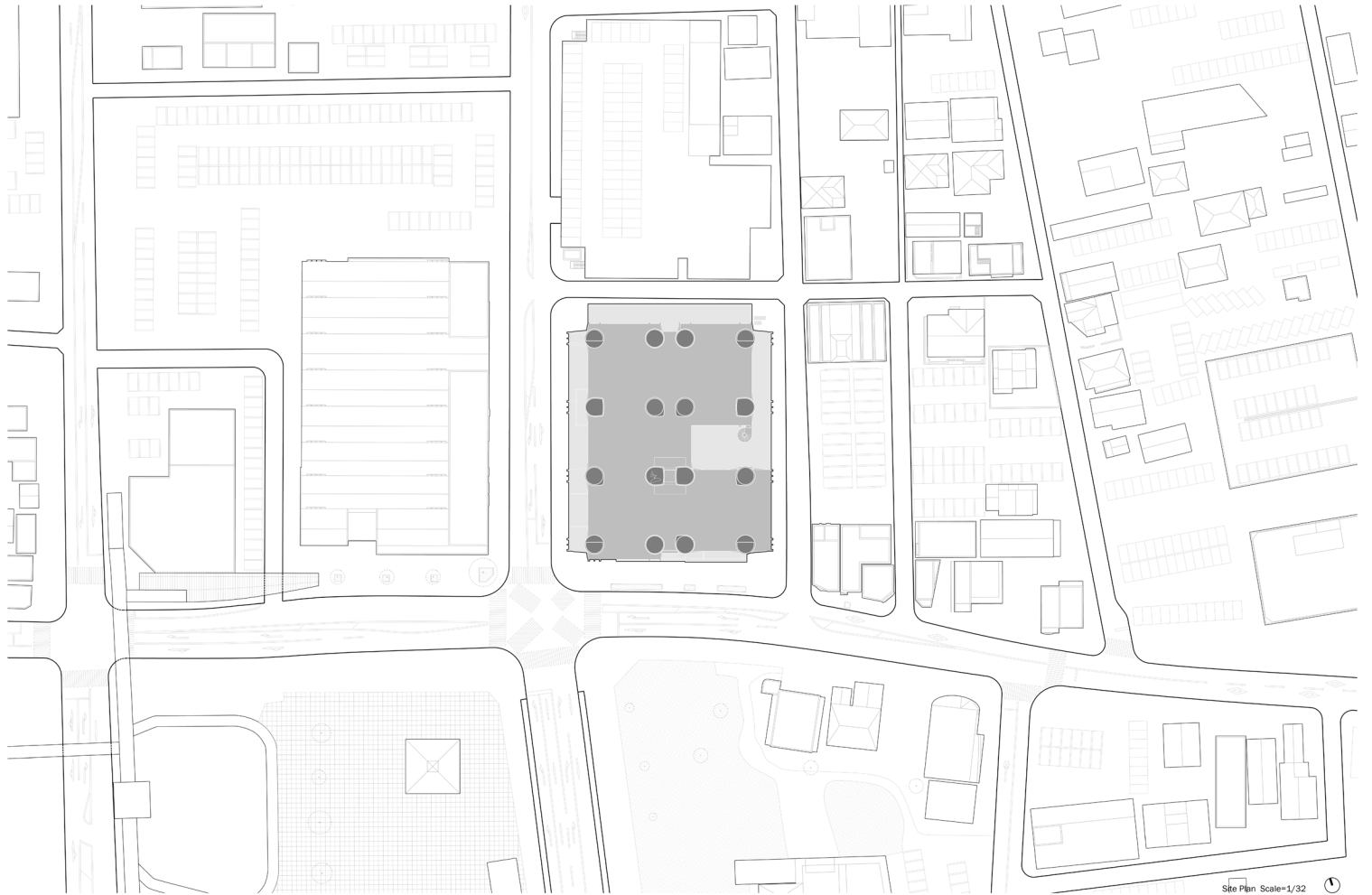

Site Plan Scale=1/32

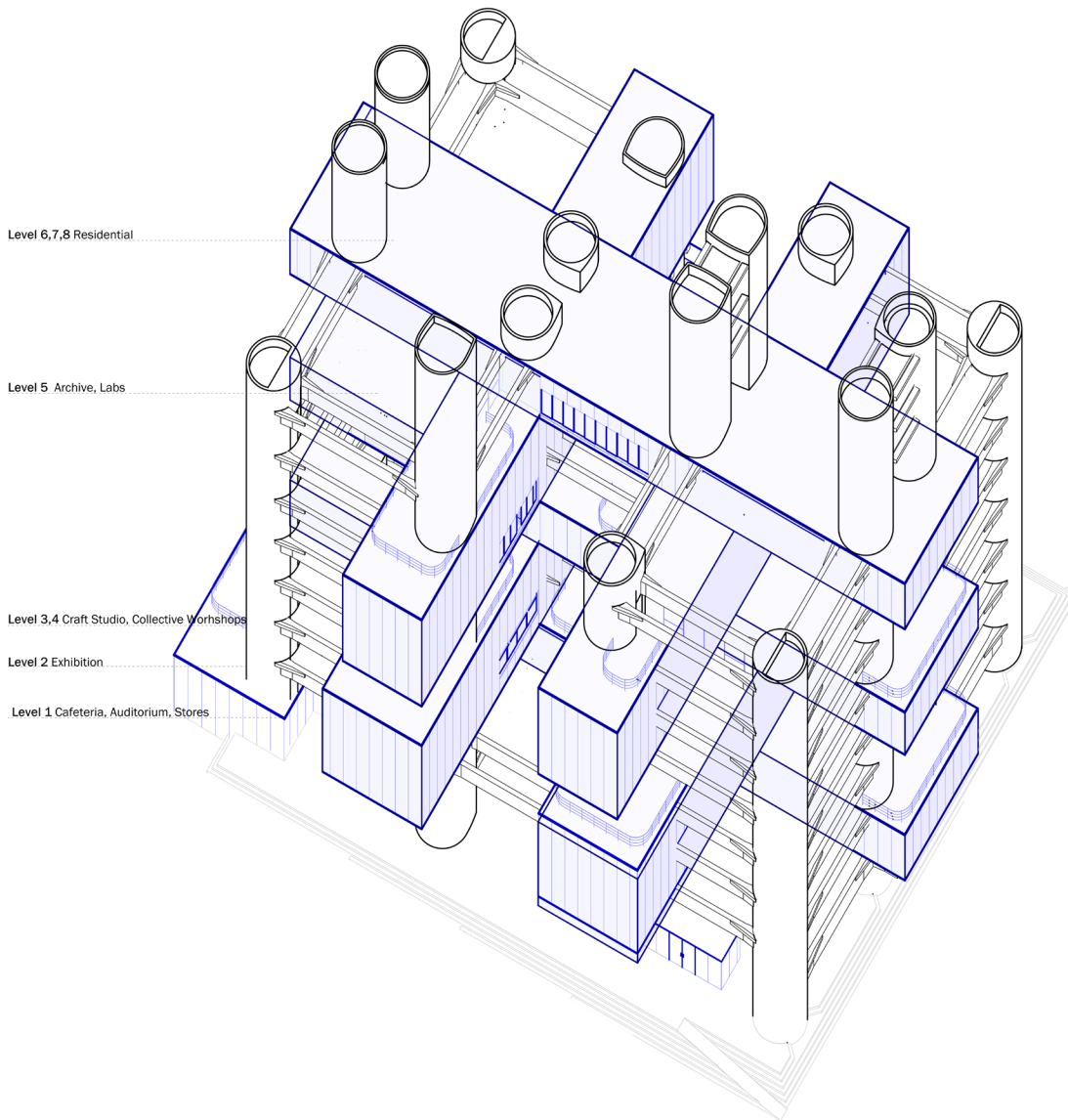

My intervention integrates with three approaches: the first one is re-hybridizing the monochrome program to combine consumption, living and production, in the same style of historical machiya, at a vertical proximity given by the existing structure.

The second approach is reducing the volumetric reading by occupying the original structure in a interlocking way, re-generating porosity that the building once had when it was built.

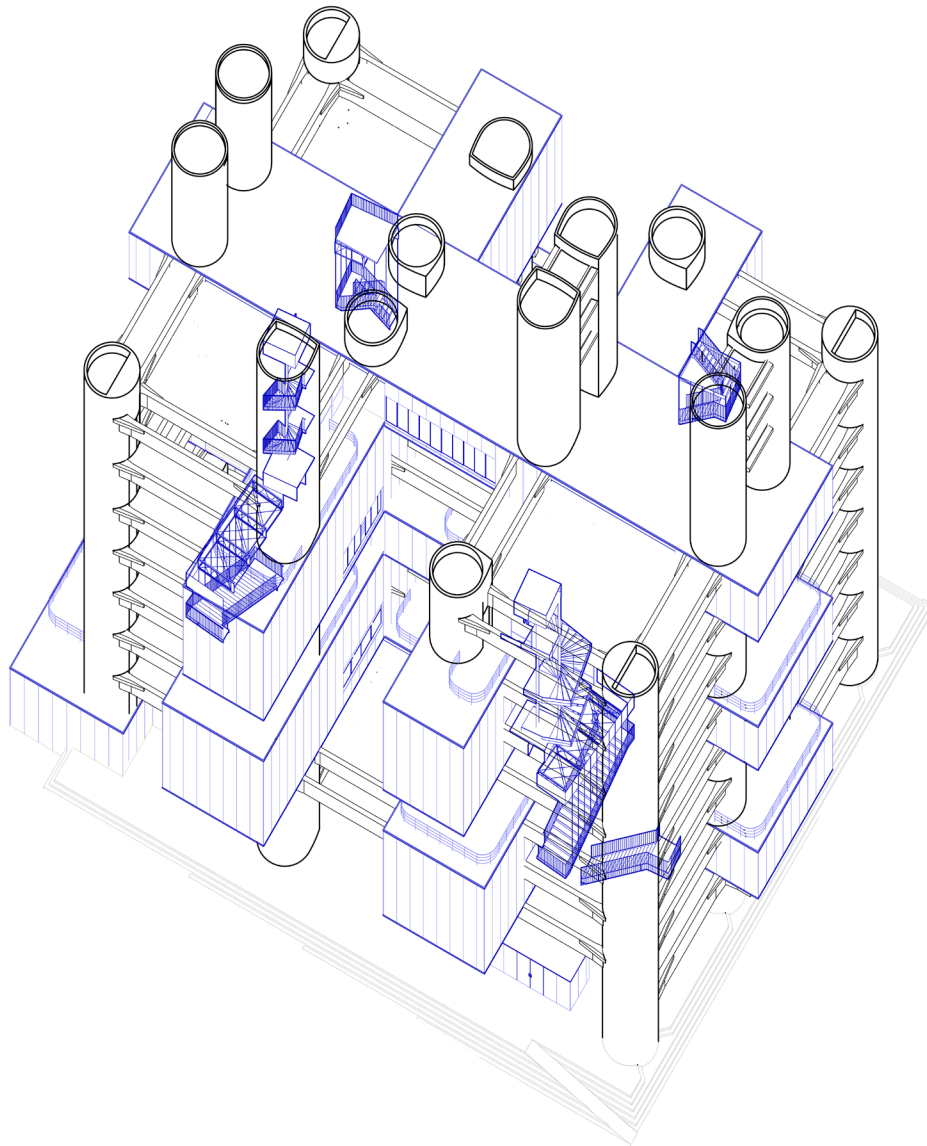

The third one is re-registering a more visible plug-in circulation system. Releasing the servant zone considered by Tange back into the generic from generic-non column space, introducing a parallel inefficient circulation language that brings back th informal social activities within Tange's lattice structure.

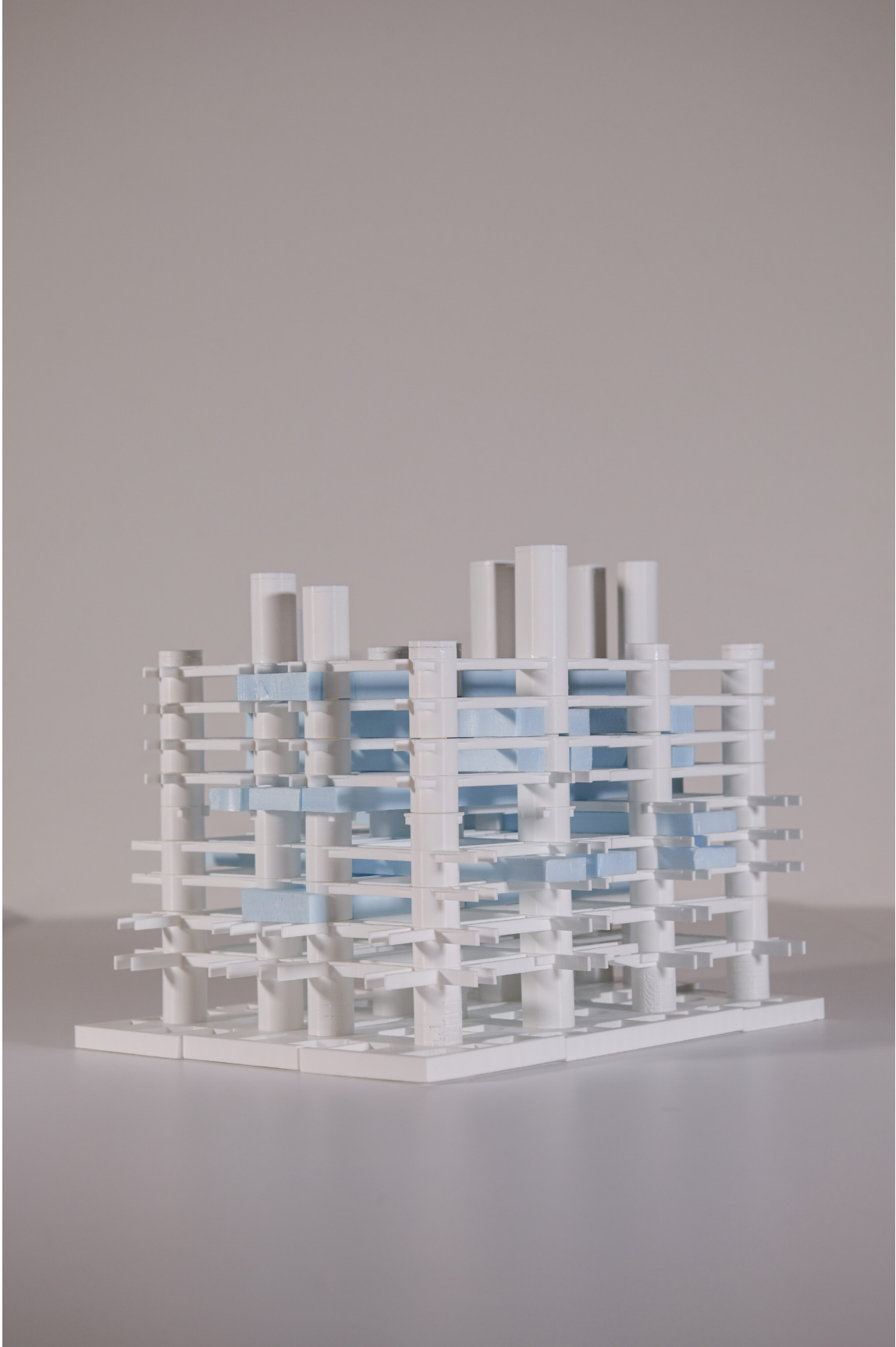

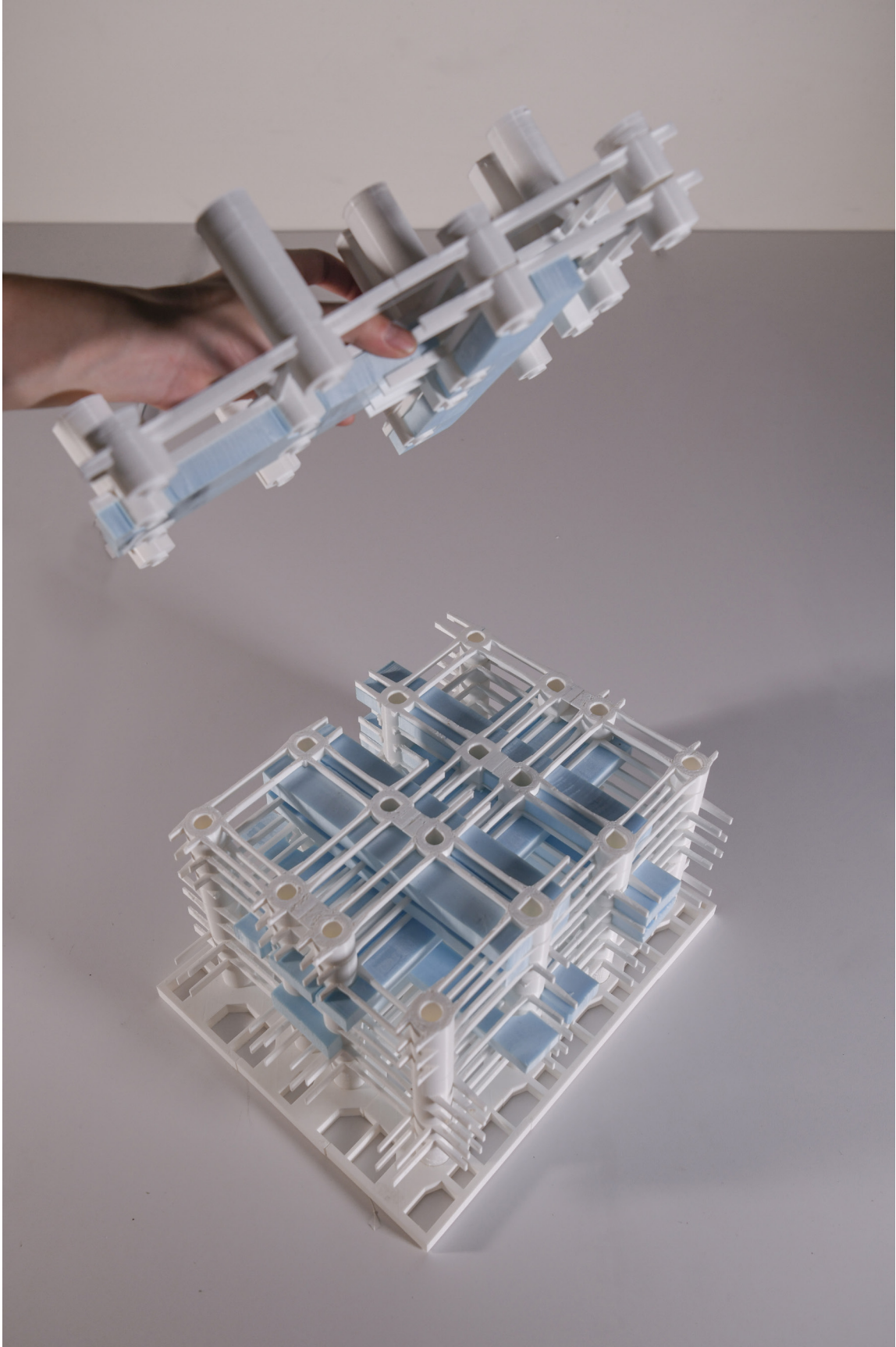

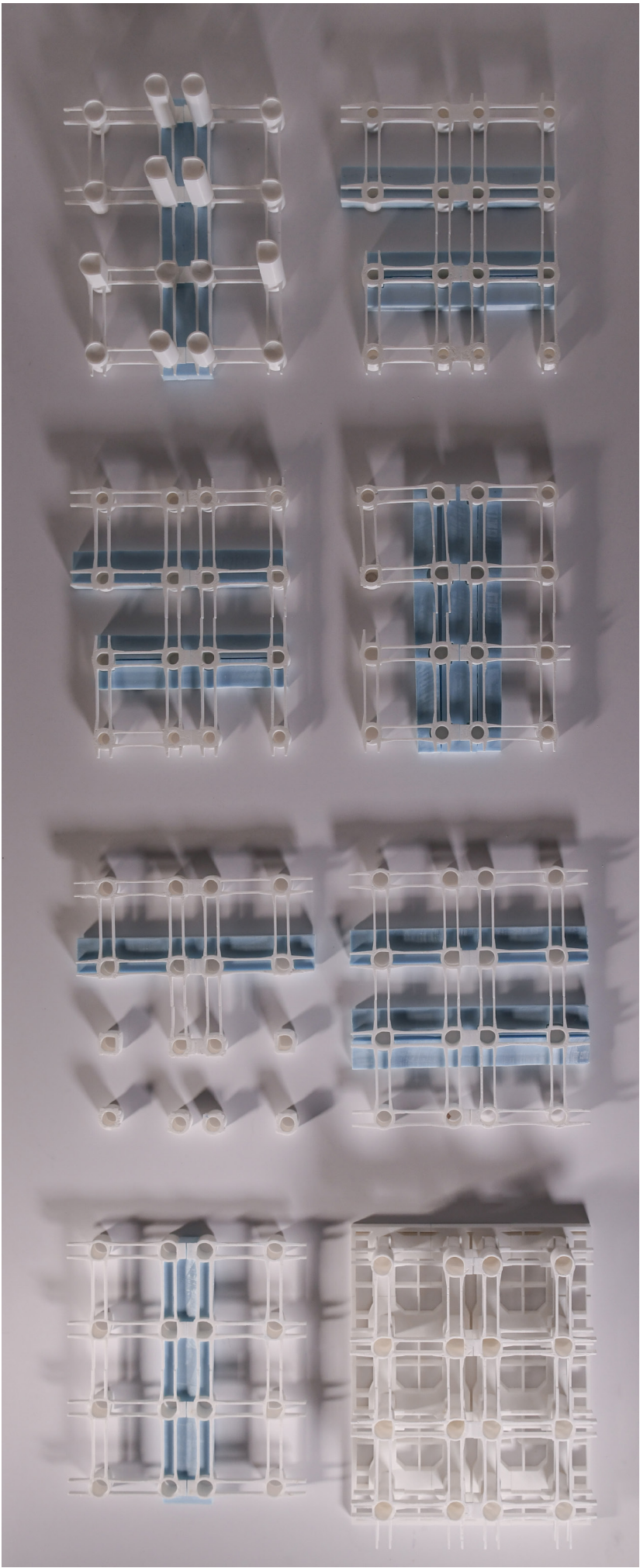

Massing Model at 1/16

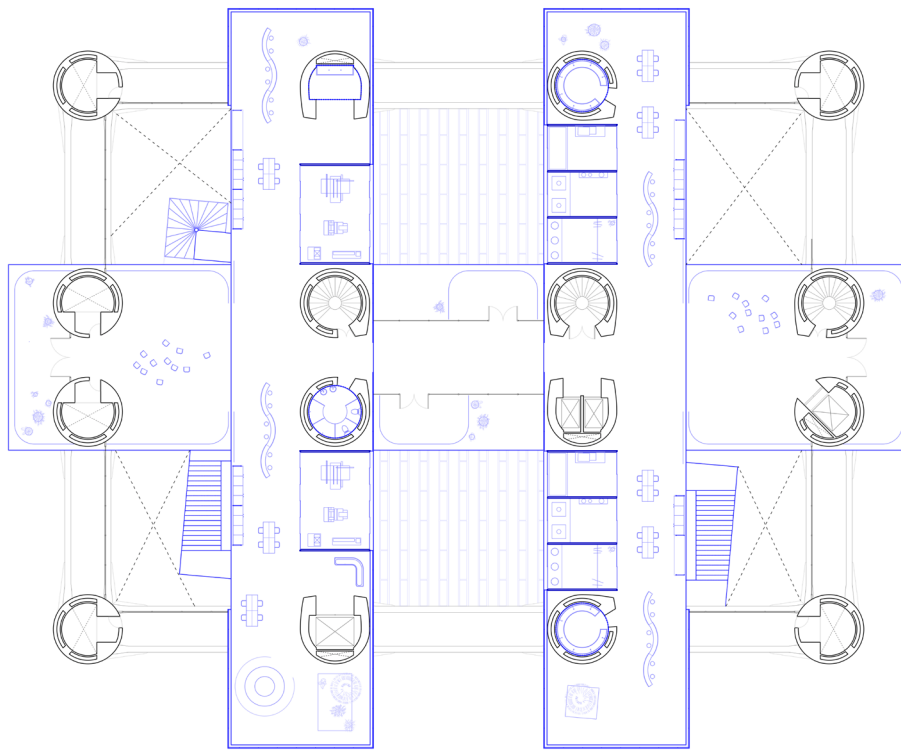

Plan L3 Individual and Collective Production Scale=1/8

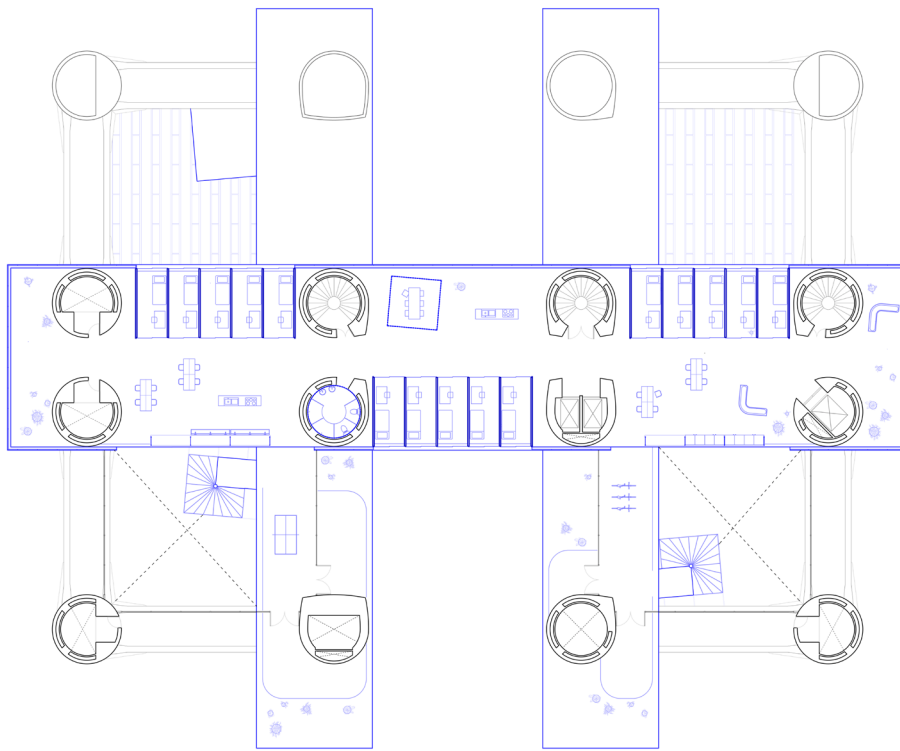

Plan L8 Collective Living Scale=1/8

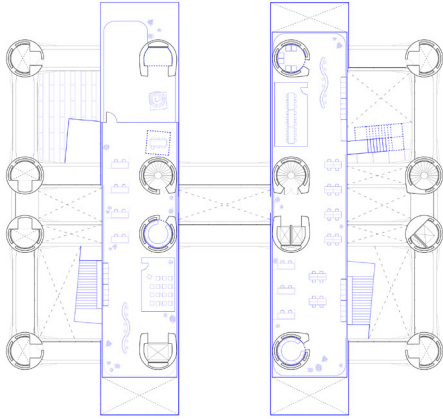

Plan L4 Collective Production Scale=1/24

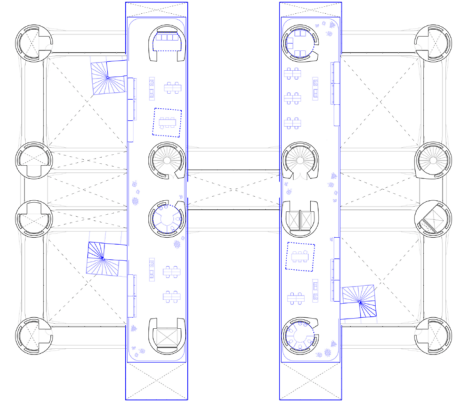

Plan L7 Collective Living Scale=1/24

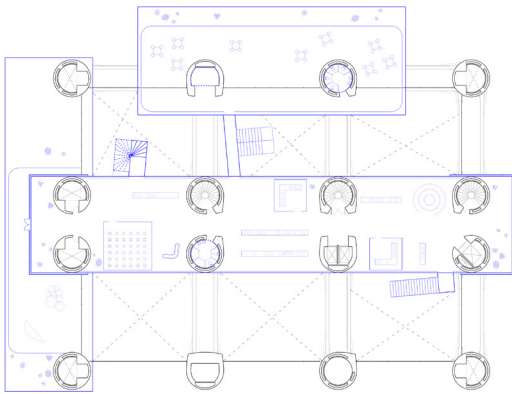

Plan L2 Exhibition, Rooftop Terrace Scale=1/24

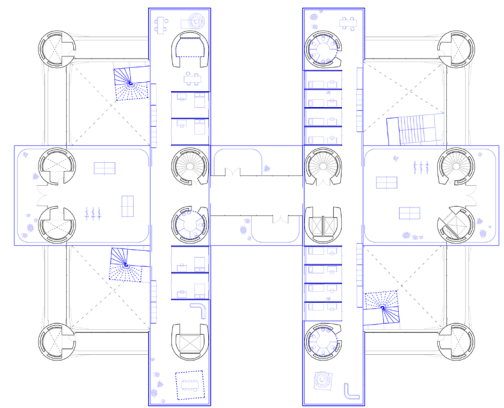

Plan L6 Collective Living Scale=1/24

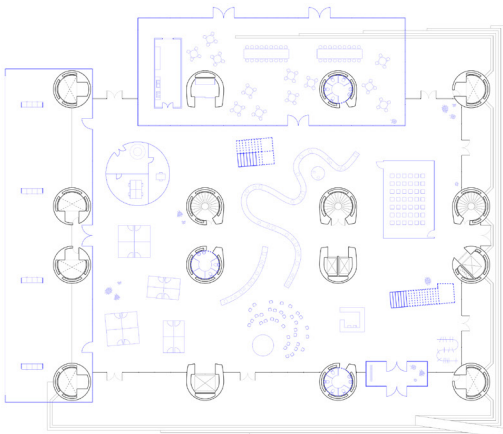

Plan L1 Stores, Exhibition, Loading, Cafe Scale=1/24

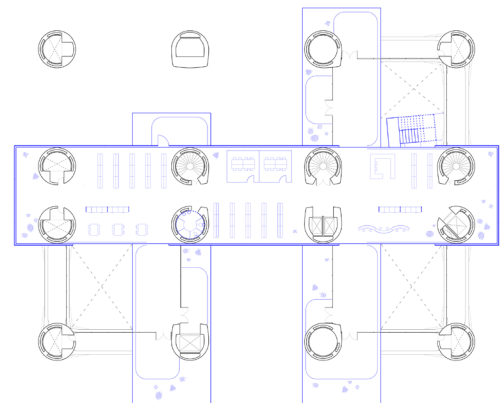

Plan L5 Archive, Library Scale=1/24

Vertically, corresponding to the original reading of accessibility by Kenzo Tange, programs are arranged from public to private in an ascending sequence. Collective Living Space at level 6-8, Archive at level 5, Collective and Individual Workshop at level 3-4, Exhibition, Office, Auditorium, Cafeteria, Stores at Level 1-2.

At the detail level, the non-flashing of interior space and exterior skin, the non-mullion double laminated glazing, and the non-flashing of new concrete slab on original structure, introduce a contrast and transparency that could be visible both inside and outside. The new volume and the space that it implies, become a series of orthogonal plug-in on the original structure.

Within each large bar plug-in, small furnitures that are designed to imply space for living and working become a smaller individual scale plug-in as an occupation of the surface of the original structure to reduce the volumetric reading. The small scale of plug-in, challenges the large module of 1960s metabolism to provide a more individual and flexible modular plug-in.

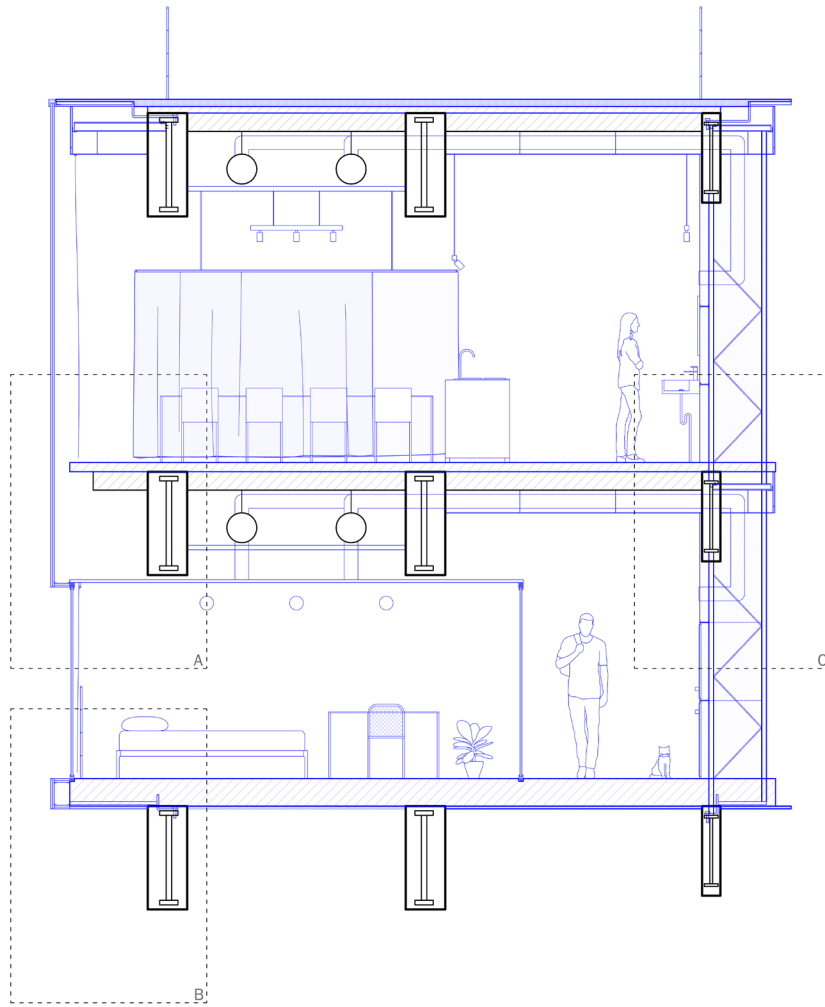

Detail Section 1 Scale=1/2

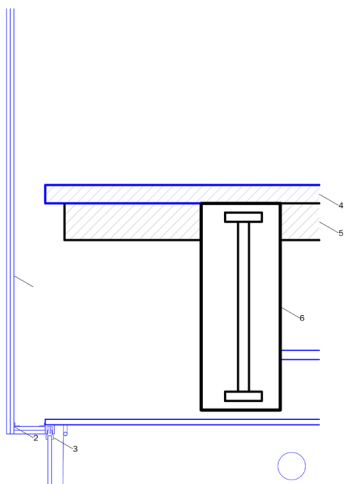

- 1 Laminated Glazing t=20mm
- 2 Steel Plate
- 3 Sliding Window
- 4 Plug-in Concrete Slab
- 5 Existing Concrete Slab
- 6 Existing Structure

A

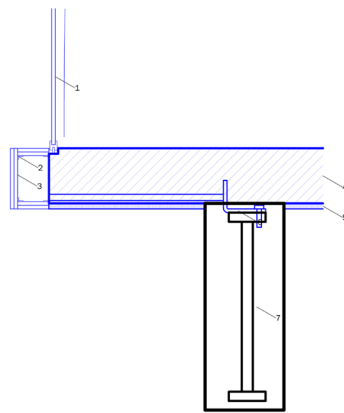

- 1 Sliding Window
- 2 Steel Plate
- 3 Laminated Glazing t=20mm
- 4 Plug-in Concrete Slab
- 5 PolyStyrene Insulation
- 6 Bolted Steel
- 7 Existing Structure

B

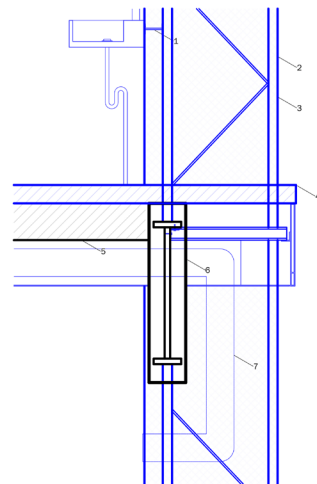

- 1 Bridging Steel
- 2 Vertical Steel Truss
- 3 Wire Mesh
- 4 Plug-in Concrete Slab
- 5 Existing Concrete Slab
- 6 Existing Structure
- 7 Ventilation Duct

C

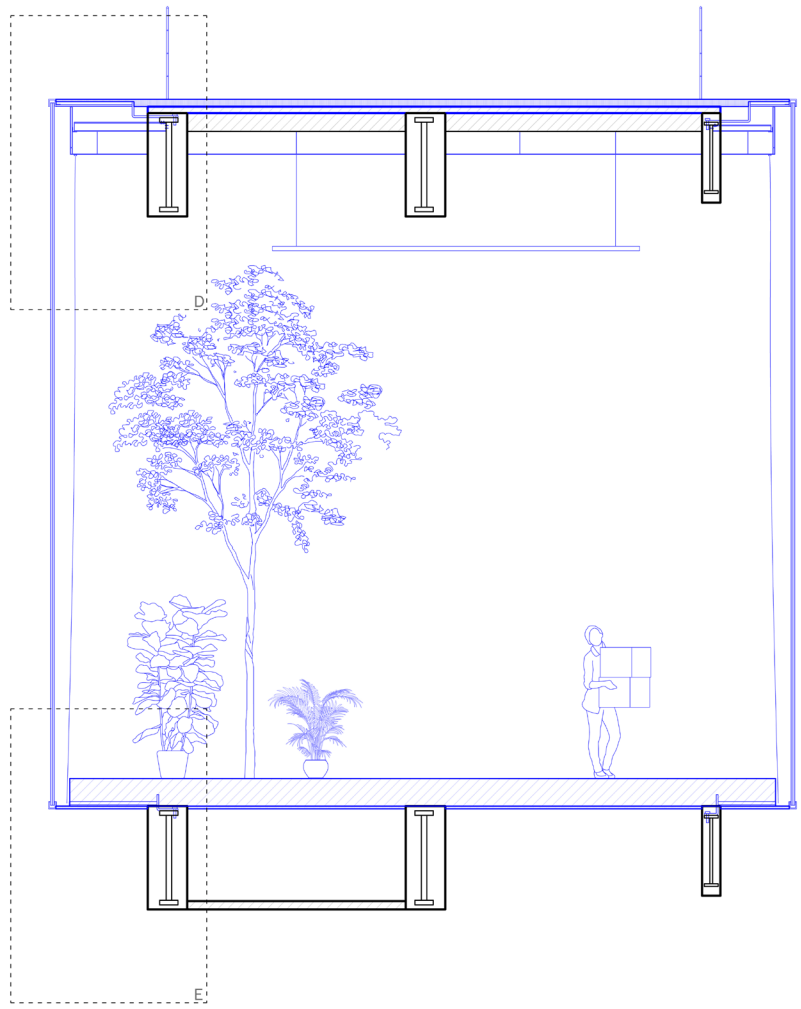

Detail Section 2 Scale=1/2

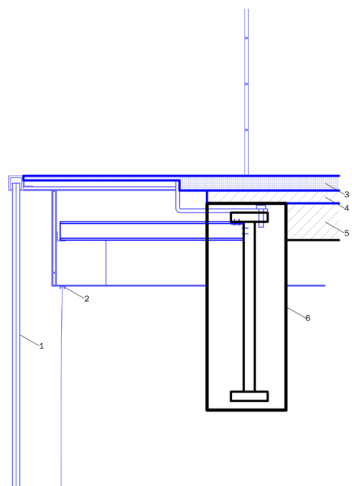

- 1 Laminated Glazing t=20mm
- 2 Rail of Curtain
- 3 Polystyrene Insulation
- 4 Plug-in Concrete Slab
- 5 Existing Concrete Slab
- 6 Existing Structure

D

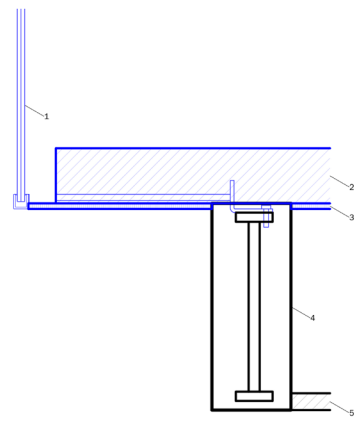

- 1 Laminated Glazing t=20mm
- 2 Plug-in Concrete Slab
- 3 Polystyrene Insulation
- 4 Existing Structure
- 5 Existing Concrete Slab

E

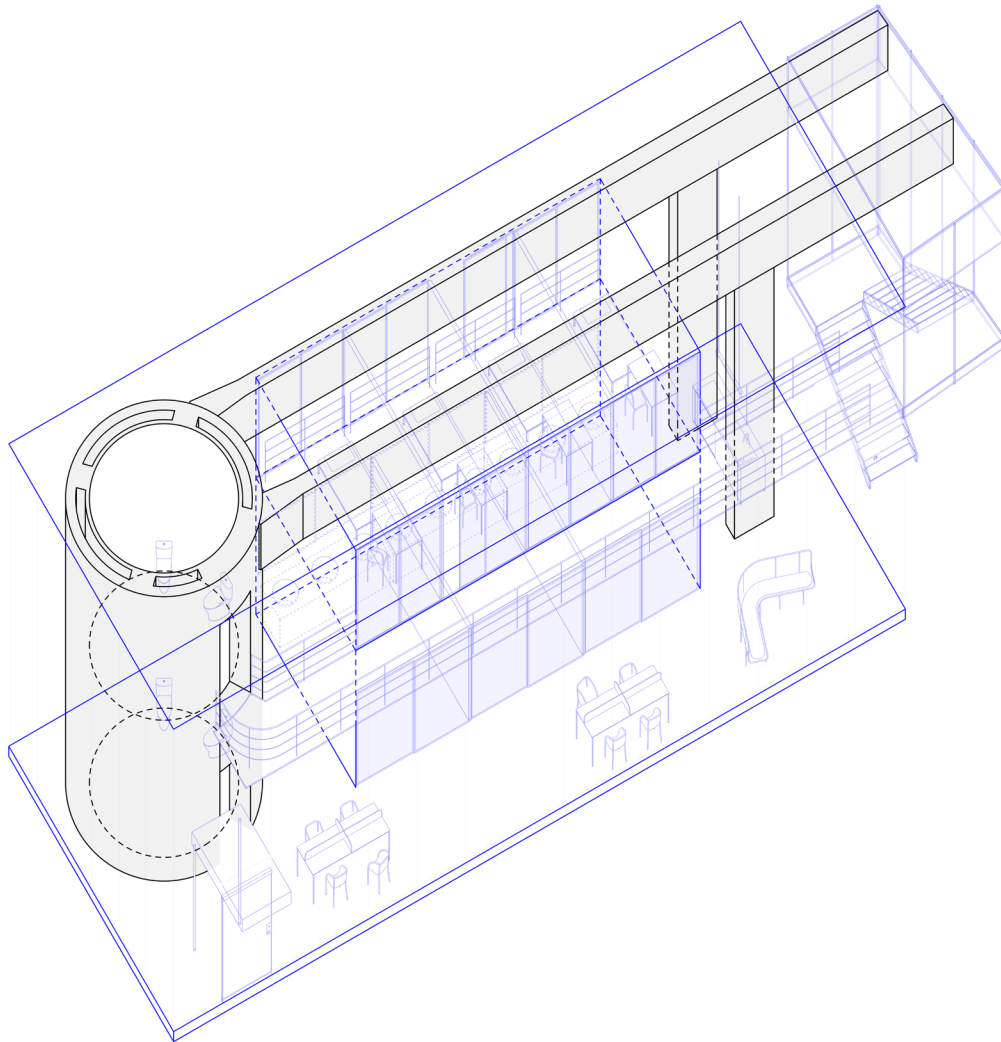

Back to the urban scale, the effect of decentralization of originally concrete structure has the potential of revitalizing the neighborhood sustainably. The debris creates autonomous structural folly that allows plural programs to inhabit underneath, replacing those vacant lots.

The decentralization of both the original structure and the plug-in further proves the reciprocal relationship of plug-in and the concrete material.



Rendering of Living Space



Rendering of Archive Space



Rendering of Collective Space



Rendering of Exhibition Space



Rendering of Living Space



Rendering from the Crossing



Rendering of Neighborhood



Rendering of Neighborhood











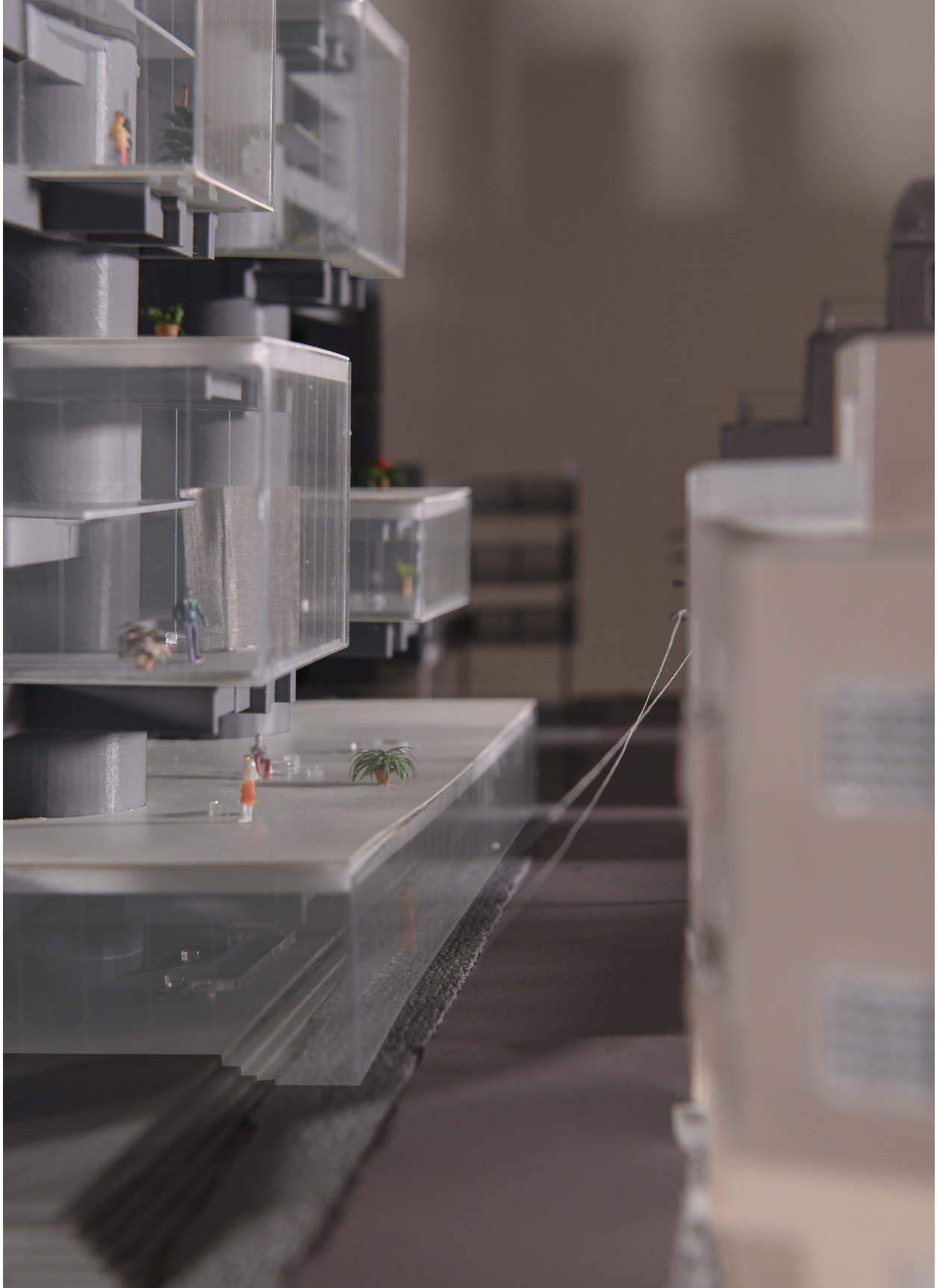

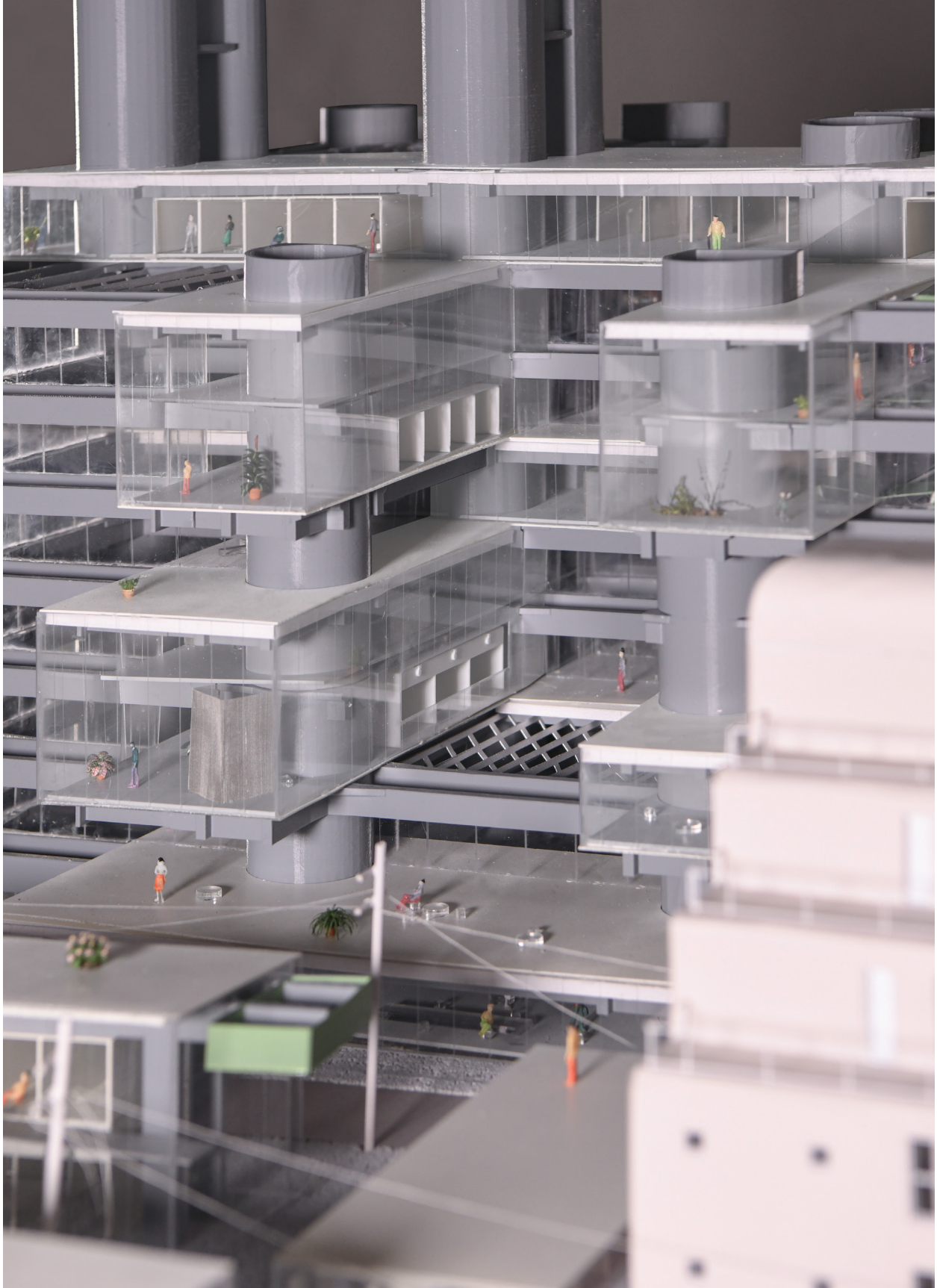





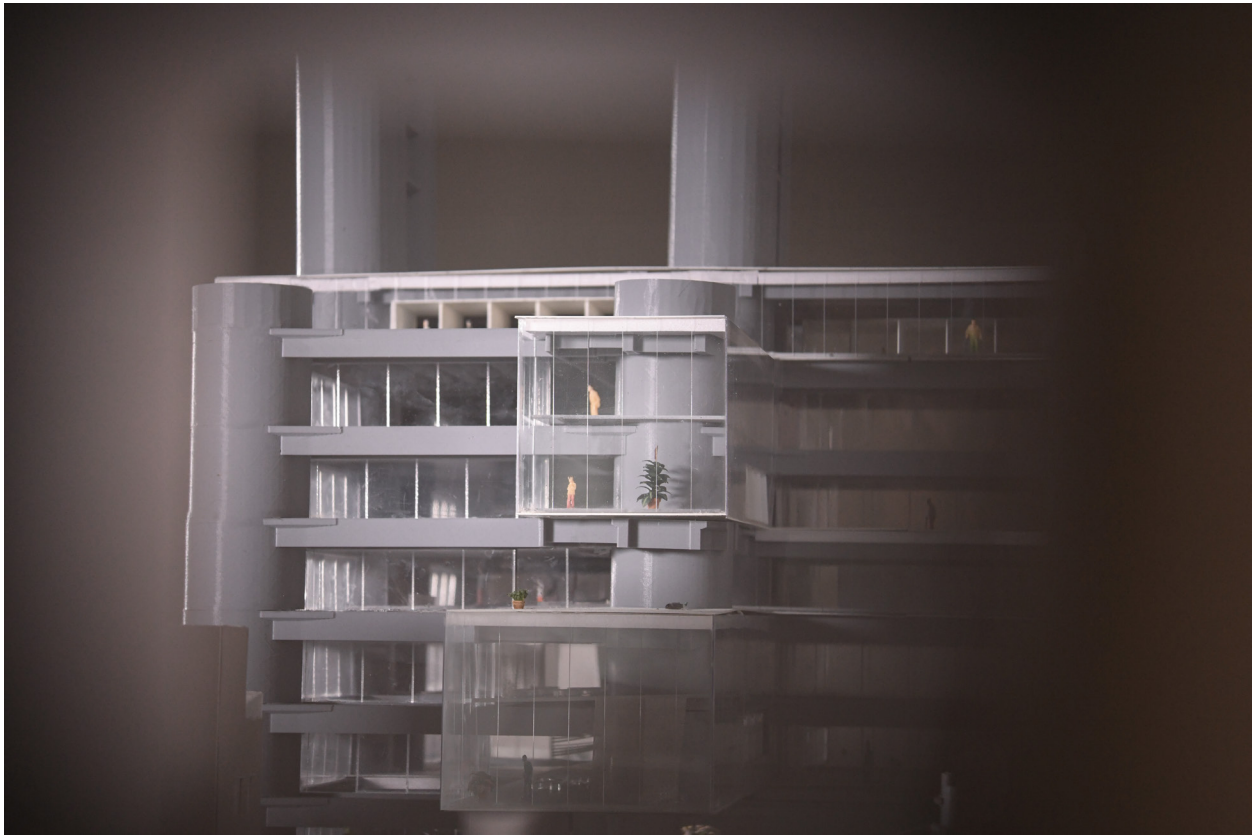







Design Conclusions

My design proposal on adapting Yamanashi Broadcasting and Press Centre presents a contemporary vision of metabolism, by scaling down the module, re-evaluating architectural program, introducing contemporary material and most importantly, re-thinking about the philosophy of metabolism: how would architecture grow or evolve in a different context within an elongated time span.

In the recent decade, post-war architecture faces an unprecedented challenge with pandemic, global economy decline and environmental issues. Many of brutalism, metabolism or concrete architecture, even with a historical value, have been demolished relentlessly.

The thesis, at its goal, reopens a fruitful discussion of potentially adapting them, due to the similarity of space, circulation, structure, material and many other architectural elements.

Citations and Reading References

Anastasia Palagina. 2019. "Preservation of the Heritage of the Metabolism Architecture in Modern Japan." *Proekt Bajkal* 16 (59).

Agnes Nyilas. 2018. *Beyond Utopia*. Taylor and Francis. <https://doi.org/10.4324/9781315165585>.

Furuhata, Yuriko. "Architecture as Atmospheric Media: Tange Lab and Cybernetics." In *Media Theory in Japan*, edited by Marc Steinberg and Alexander Zahlten, 52-79. Durham: Duke University Press, 2017.

Gardner, William O., and Project Muse. 2020. *The Metabolist Imagination : Visions of the City in Postwar Japanese Architecture and Science Fiction*. Minneapolis: University of Minnesota Press.

Gerow, Aaron. "Early Theories of Television in Japan." In *Media Theory in Japan*, edited by Marc Steinberg and Alexander Zahlten, 33-51. Durham: Duke University Press, 2017.

INAX, Kabushiki Kaisha. 2008. *Tokushū Tōkyō metaborizumu nisenjū / fifuti iyāzu afutā senkyūhyaku rokujū Tōkyō: Inakkusu Shuppan*.

Jacquet, Benoît, and Jeremie Souteyrat. 2020. *L'architecture du futur au Japon : utopie et métabolisme = Architecture of the future in Japan : utopia and metabolism = Nihon no mirai kenchiku : yūtopia to metaborizumu*. Poitiers: Le Léopard Noir Editions.

Kitayama, Koh, Yoshiharu Tsukamoto, Ryūe Nishizawa, and International Architectural Exhibition. 2010. *Tokyo Metabolizing = [Tōkyō Metaboraijingu]*. Tokyo, Japan: TOTO Pub

Koolhaas, Rem, Hans Ulrich. Obrist, Kayoko. Ota, James Westcott, and Office for Metropolitan Architecture. AMO. 2011. *Project Japan : Metabolism Talks*. Köln ; London: Taschen.

Kuan, Seng. 2011. "Tange Kenzō's Architecture in Three Keys: As Building, as Art, and as the City". ProQuest Dissertations Publishing.

Kuan, Seng. 2018. "'JAPAN IN ARCHITECTURE: GENEALOGIES OF ITS TRANSFORMATION'." *Artforum International* 56 (5): 93.

Kuan, Seng., Yukio Lippit, and Harvard University. Graduate School of Design. 2012. *Kenzō Tange : Architecture for the World*. Baden : London: Lars Müller ; Springer [distributor].

Kultermann, Udo, Kenzō Tange, and H. R Muhl. 1989. *Kenzo Tange*. 1st Spanish/English ed. Barcelona: Gustavo Gili.

Kurokawa, Kishō, and Aldo. Castellano. 1996. *Kisho Kurokawa : Abstract Symbolism*. Milano: L'Arcaedizioni.

Lin, Zhongjie. *Kenzō Tange and the Metabolist Movement: Urban Utopias of Modern Japan*. New York: Routledge, 2010.

- Lindner, Christoph. 2019. "Brutalism, Ruins, and the Urban Imaginary of Gentrification." In *The Routledge Companion to Urban Imaginaries*, 1st ed., 275–87. Routledge. <https://doi.org/10.4324/9781315163956-21>.
- Maki, Fumihiko. *Nurturing dreams. Collected Essays on Architecture and the City*. Cambridge: MIT Press, 2008.
- Metabolism, the City of the Future*. 2011. Tokyo: Mori Art Museum.
- Prudon, Theodore H. M. 2008. *Preservation of modern architecture*. Hoboken, N.J.: Wiley.
- Riani, Paolo, Kenzo Tange, and Kenzō Tange. 1971. *Kenzo Tange*. Vol. 8. Luzern: Kunstkreis.
- Ross, Michael Franklin. 1978. *Beyond Metabolism : the New Japanese Architecture*. New York: Architectural record books.
- Tange, Kenzō 1913. *The Kenzō Tange Archive*.
- Tange, Kenzō 1961. *A Plan for Tokyo, 1960 : Toward a Structural Reorganization*. s.l.: s.n.
- Tange, Kenzō 1972. *Images of the Future Urban Environment*.
- Tange, Kenzō 1961. *Movements from Architecture Toward Construction*.
- Tange, Kenzō and Massimo Bettinotti. *Kenzō Tange 1946-1996: Architecture and Urban Design*. Milano: Electa, 1996.
- Tange, Kenzō, Noboru Kawazoe, Yoshio Watanabe, and Asahi Shinbunsha. 1962. *Ise : Nihon kenchiku no genkei*. Tōkyō: Asahi Shinbunsha.

Photo

Neighbourhood and Interior Today Photos by Kanemasa Furuya

Interior and Exterior 1966 Photos by Shinken-chiku-sha

Image on Page 4: Utagawa Hiroshige, Tea house in Hakusen district (Tea House Machiya); Kofu Shopping Guide, 1854; [https://kotobank.jp/word/%E7%B4%BA%E5%B1%8B\(%E3%81%93%E3%81%86%E3%82%84\)-1533651](https://kotobank.jp/word/%E7%B4%BA%E5%B1%8B(%E3%81%93%E3%81%86%E3%82%84)-1533651) (dyeing house); <https://nipponnowaza.com/kousyuinden-2/> (Kofu Inden); Utagawa, Kunitaru. Daiichi Daiku Kyōbashi yori Shinbashi made renga ishizukuri shōka hanjō kisen sōtaku seikei (Meiji Restoration Scene); https://www.tripadvisor.com/LocationPhotoDirectLink-g298564-d11878825-i361386768-Toraya_Kyoto_Gallery-Kyoto_Kyoto_Prefecture_Kinki.html (silk production); <https://tivoli-america.com/about/> (aerial factory view); https://en.wikipedia.org/wiki/File:Air_raid_Kofu-City.jpg (Kofu bombing)

Labor

Painting and sanding model bases: Alex Yang, Borler Wu

Site Model Utility Pole Planter: Weiyong Zhang

Model Laser-cutting and Assembly: Yun Ki Cheung, Isadora Faustina Panjaitan, Mic Ma, Yuchen Zhao, Sunah Jeong

Furniture Assembly: Hugo Ho, Ethan Zheng

Human Figure Adding: Rebecca Shen

Plotting and Model assembly: Inmo Kang