



# 'Functional Follies' for an Urban Slum

## Citation

Akakpo, Kofi. 2020. 'Functional Follies' for an Urban Slum. Master's thesis, Harvard Graduate School of Design.

## Permanent link

<https://nrs.harvard.edu/URN-3:HUL.INSTREPOS:37369503>

## Terms of Use

This article was downloaded from Harvard University's DASH repository, and is made available under the terms and conditions applicable to Other Posted Material, as set forth at <http://nrs.harvard.edu/urn-3:HUL.InstRepos:dash.current.terms-of-use#LAA>

## Share Your Story

The Harvard community has made this article openly available.  
Please share how this access benefits you. [Submit a story](#).

[Accessibility](#)

**'FUNCTIONAL FOLLIES' FOR AN URBAN SLUM**

A Thesis Submitted to the Department of Architecture  
Harvard University Graduate School of Design, by

**KOFI AKAKPO**

In Partial Fulfillment of the Requirements for the Degree of  
[Master of Architecture]

**DECEMBER, 2020**

**“The author hereby grants Harvard University permission to reproduce and distribute copies of this thesis, in whole or in part, for educational purposes.”**

(signature)

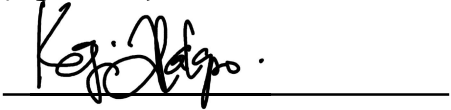

---

[Kofi Akakpo]

(signature)



---

[Mohsen Mostafavi]

# **'FUNCTIONAL FOLLIES' FOR AN URBAN SLUM**

Kofi Akakpo

Advisor: Mohsen Mostafavi

Fall, 2020

*“The challenge for Africa is no less than the restoration of its intellectual freedom and a capacity to create – without which no sovereignty is conceivable.”*

COVID-19: An open letter from African intellectuals to Africa's leaders | African Arguments, April 18th, 2020

This thesis derives from an interest in the ways in which people can imagine and dream beyond their means.

The thesis rejects the general narrative that African architecture has to primarily satisfy perceived needs.

Narratives about trying to revive what was before European conquest of the continent are doomed to fail.

This attitude denies Africans the freedom to create by looking within, instead it insists on African creativity only as a relative ***other***, giving the impression that colonialism is the constant present lens through which to see the continent.



Through this, the African has been denied the right to dream. Architecture on the continent has therefore ignored the imaginativeness of the subjects it designs for.



'Architecture' in Ghana today.



'Architecture' in Ghana before.



Aljana Moons-Twins Carriage | Alexis Paskine, 2015



“Potentiality” | Alun Bey, 2017



“3018” Back to the Future



Grace Jones



“AfroGallonism” | Serge Attuqwei Clottey





For Chale Wote Street Festival | DJ Steloo Live



For Chale Wote Street Festival | DJ Steloo Live



Sound Art Performance | DJ Steloo Live

African architecture needs to be in a position where it can dream and imagine things.

## SITE



1000 mi

**Africa**



150 mi

**Ghana**

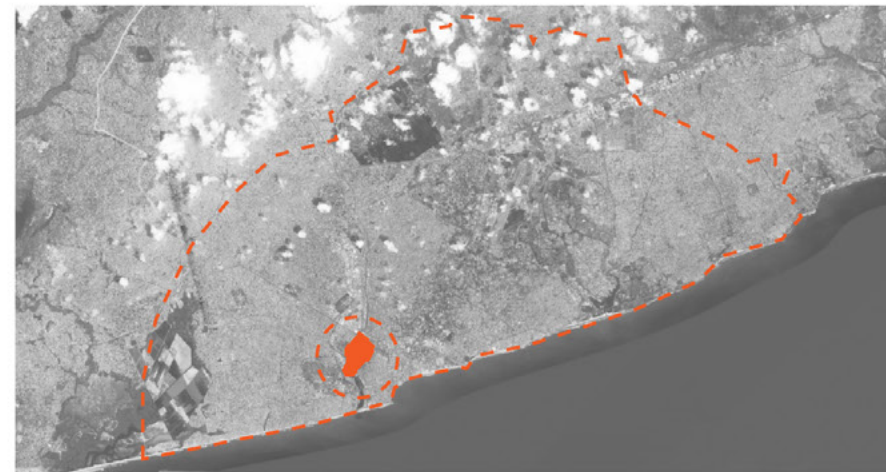

6 mi

**Accra**



0.5 mi

**Agbogbloshie**

From Continent to Site



Aerial View of Agbogbloshie





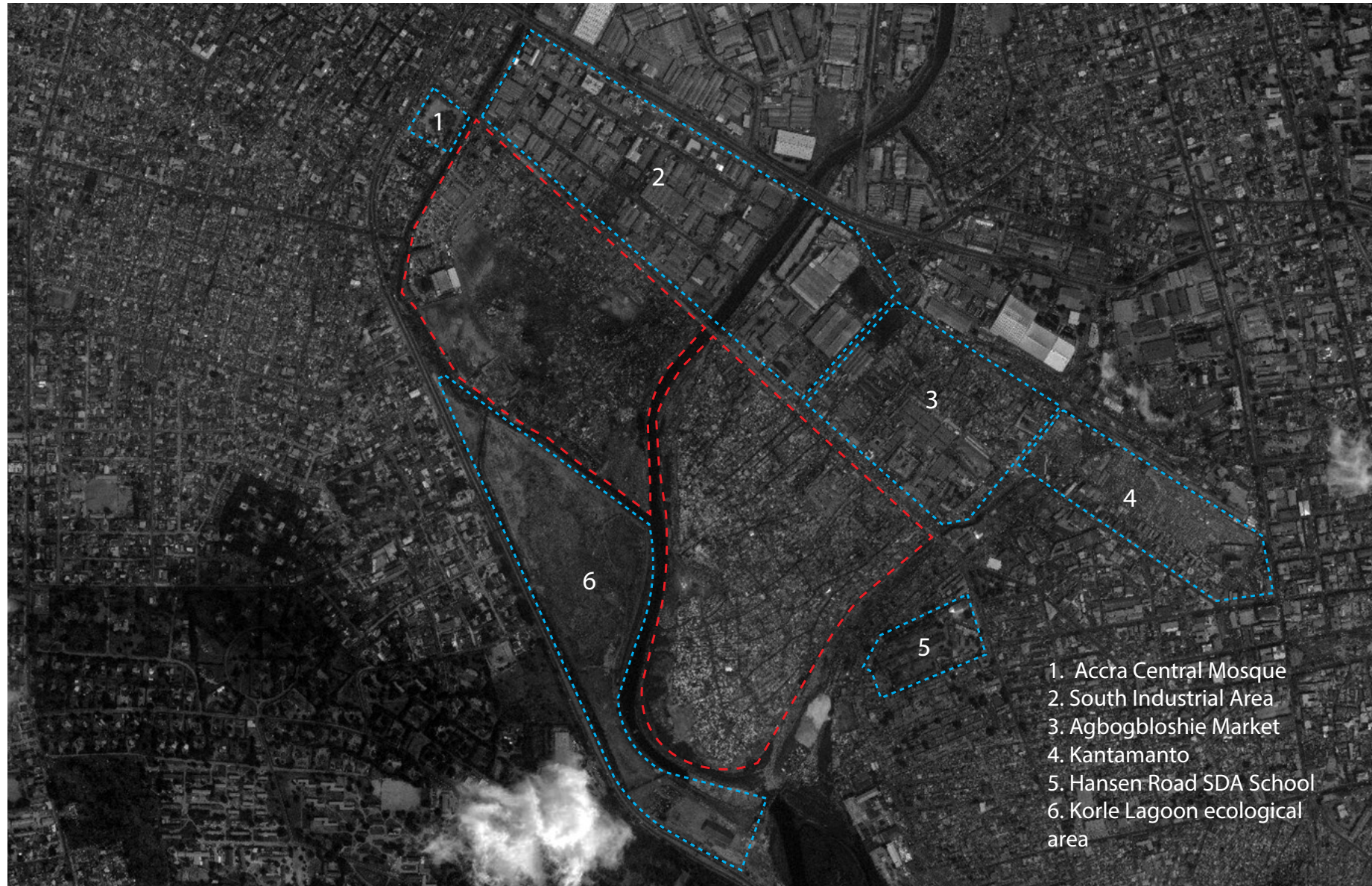

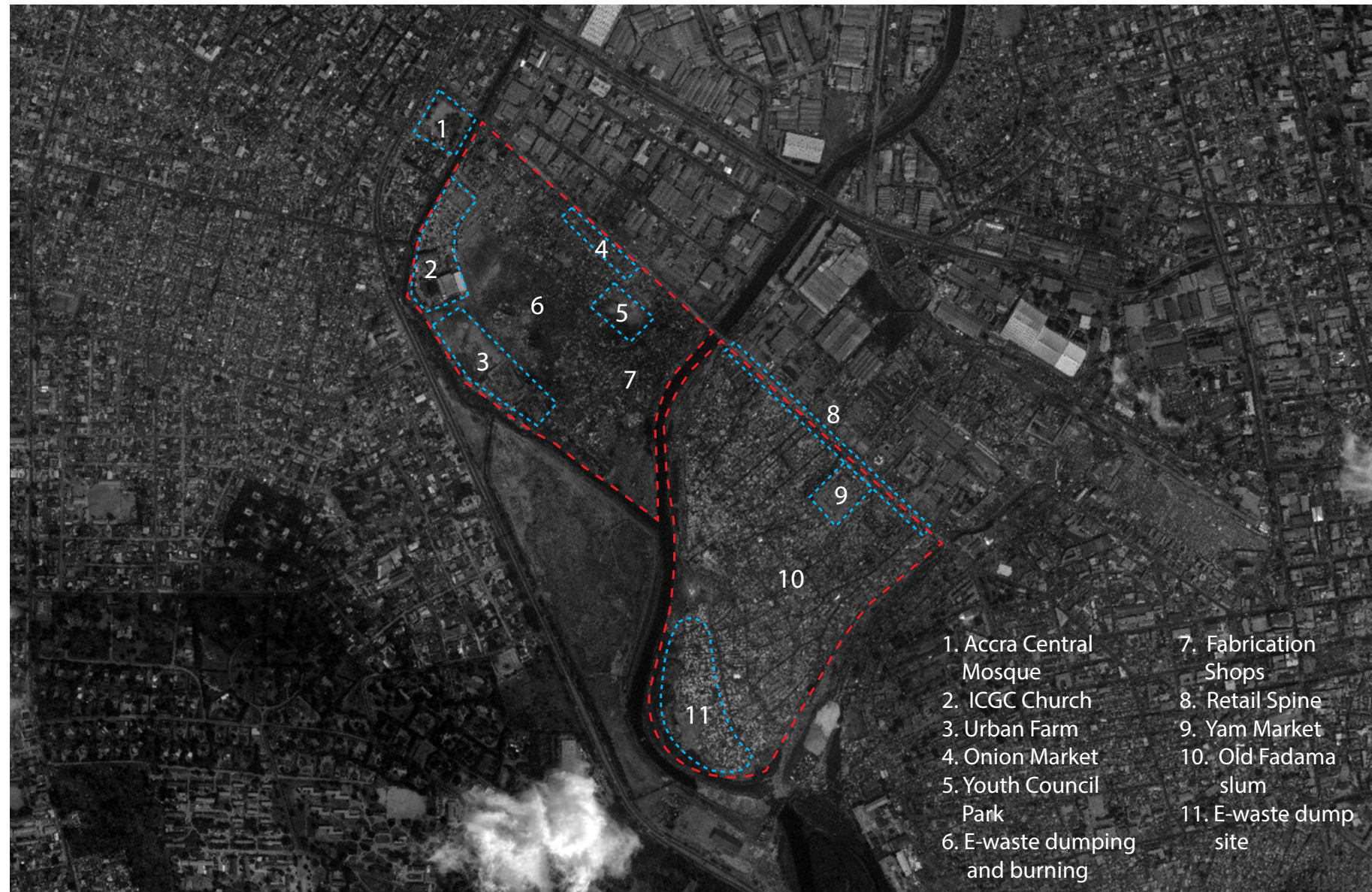



People of Agbogbloshie

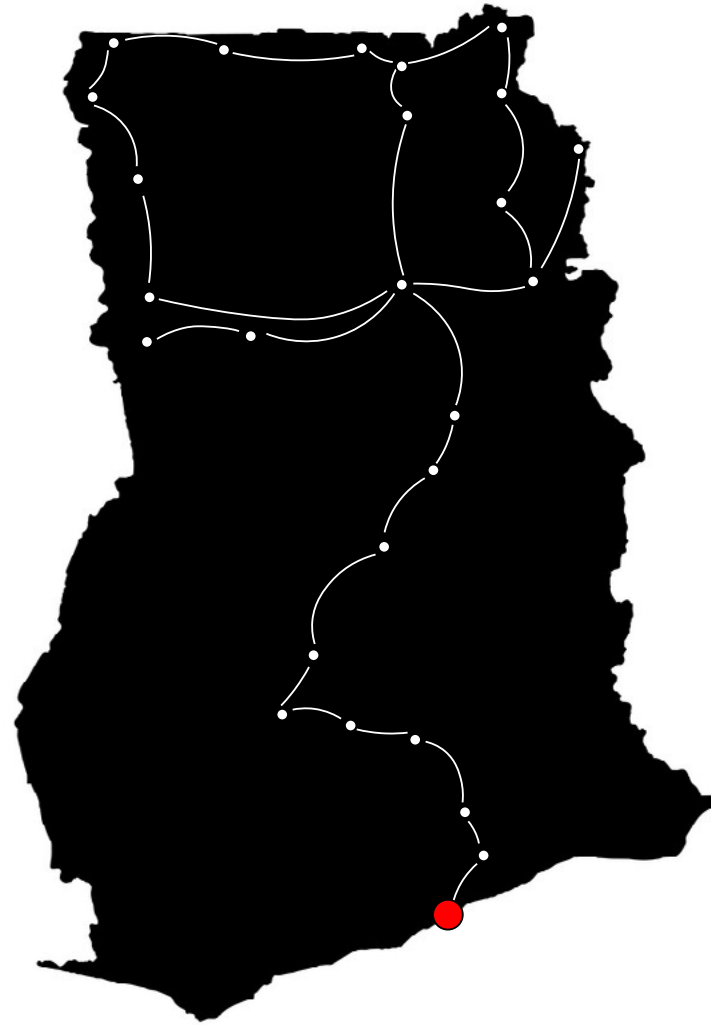

Migration route from the North to Accra



Site Photos



Agbogbloshie in the media



A curious mind at Agbogbloshie

*“Slums are not the problem, but rather the solution.”*

John F C Turner



# PROJECT

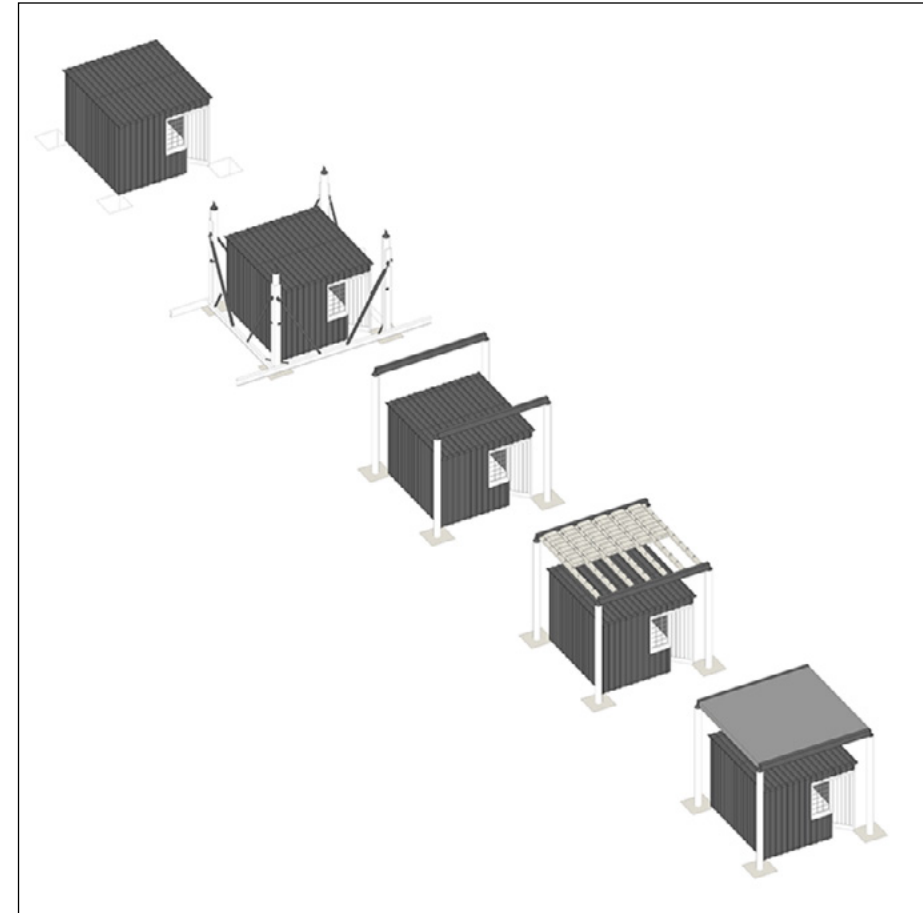
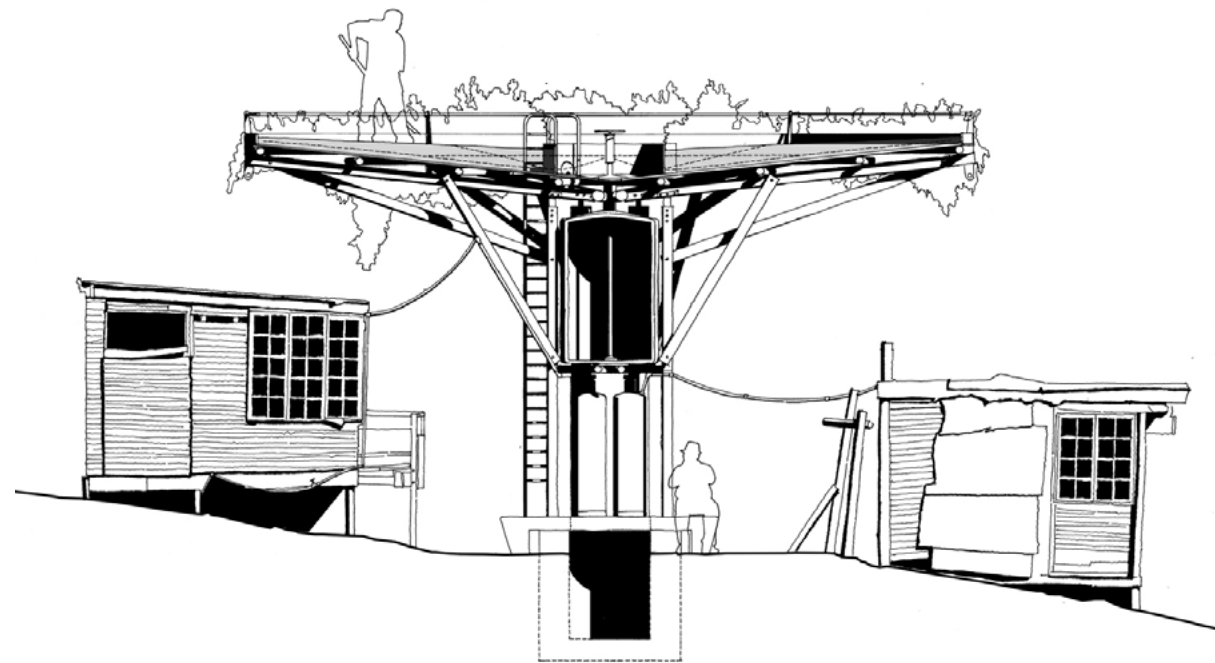

Table House | Noero Architects



Productive (Re)public | Noero Architects

## **Folly (architecture)**

Folly, (from French folie, “foolishness”), also called EYECATCHER, in architecture, a costly, generally nonfunctional building that was erected to enhance a natural landscape.

## **Masque (entertainment)**

Masque, also spelled mask, festival or entertainment in which disguised participants offer gifts to their host and then join together for a ceremonial dance.

*Encyclopedia Britannica*



A classical folly.

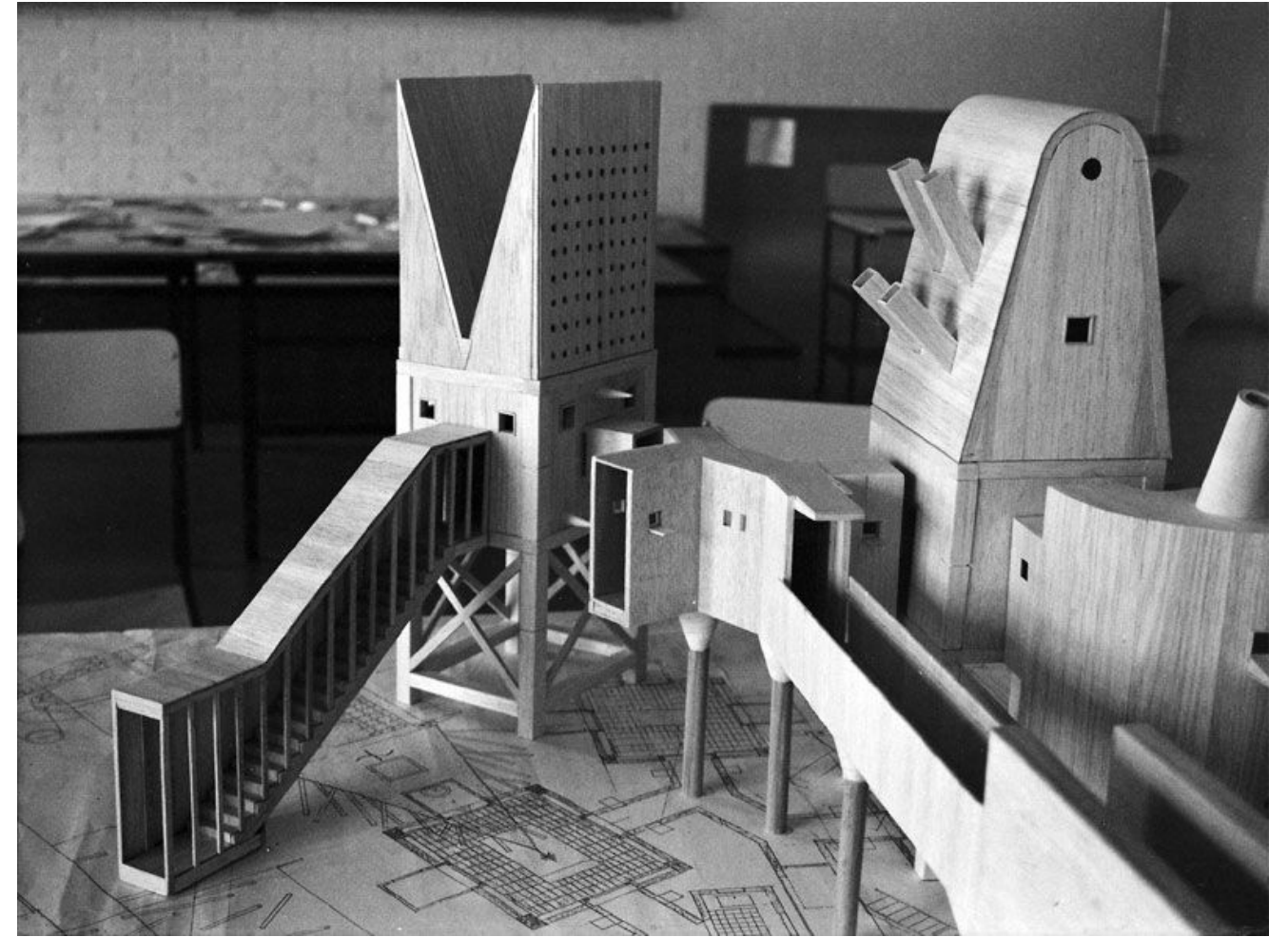
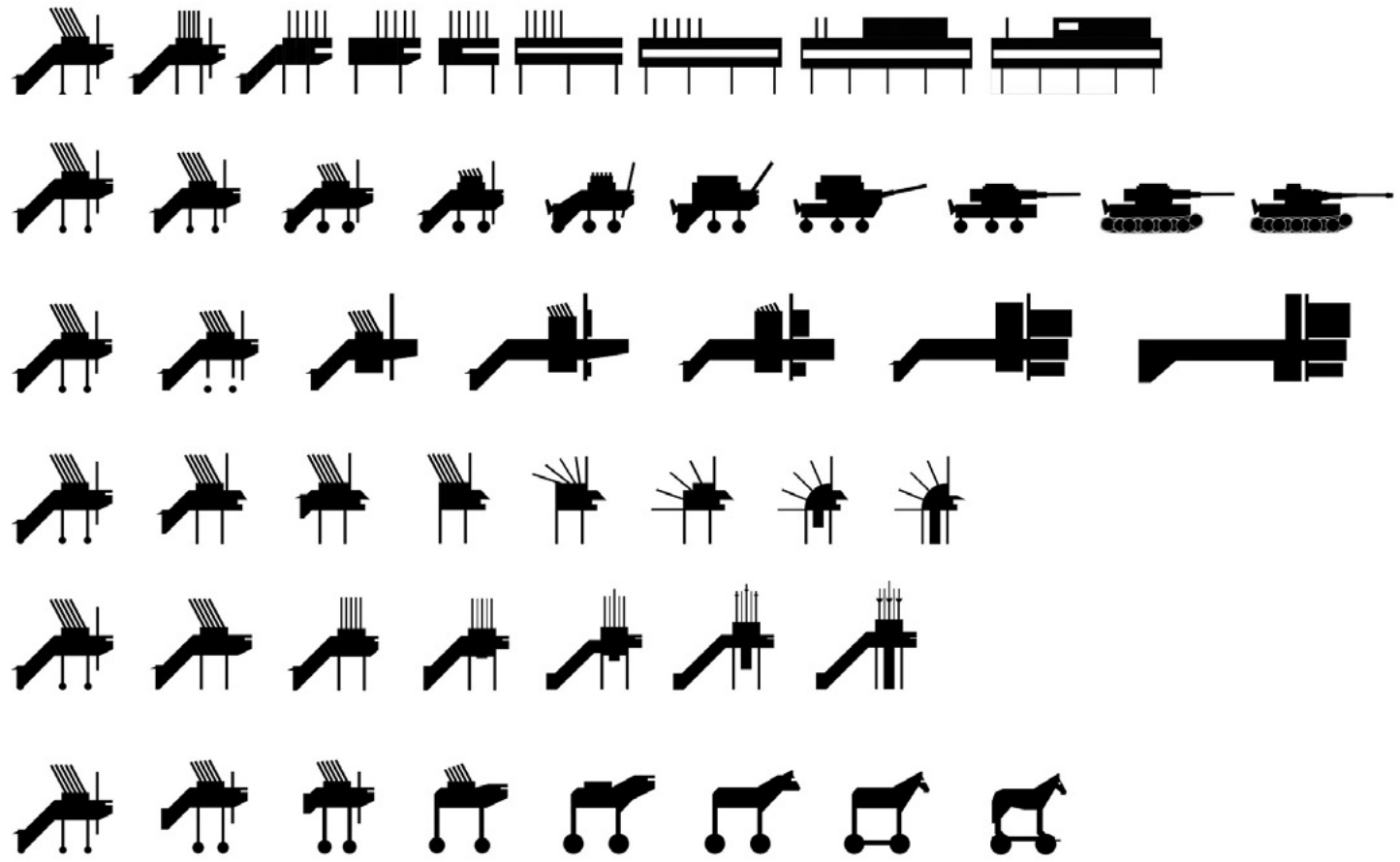

Moving Masques | John Hejduk



Site Plan



Major Circulation Paths





Important Nodes



Initial Sketch

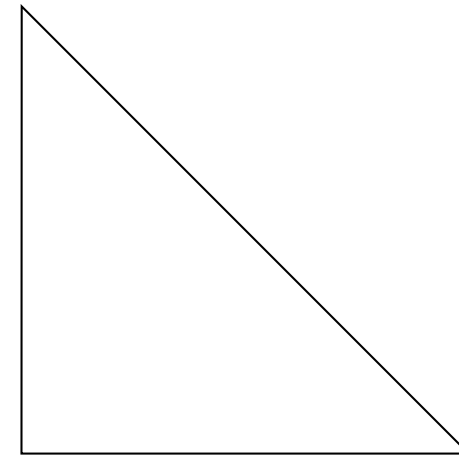
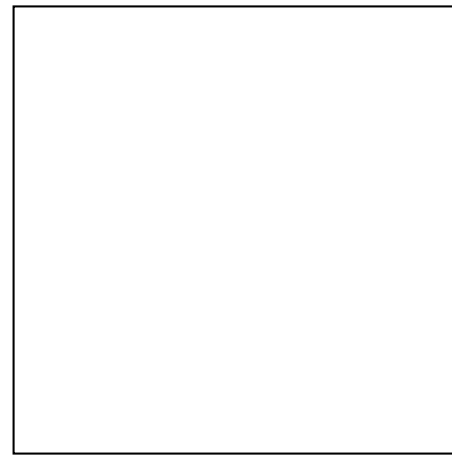
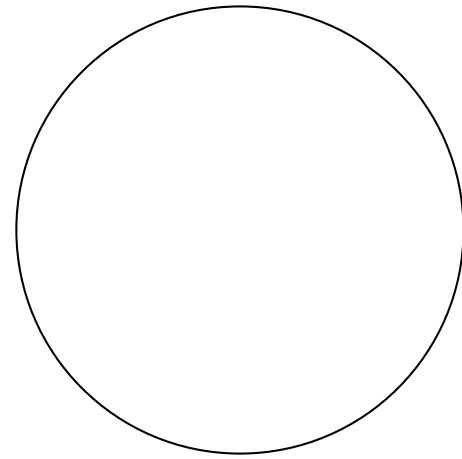

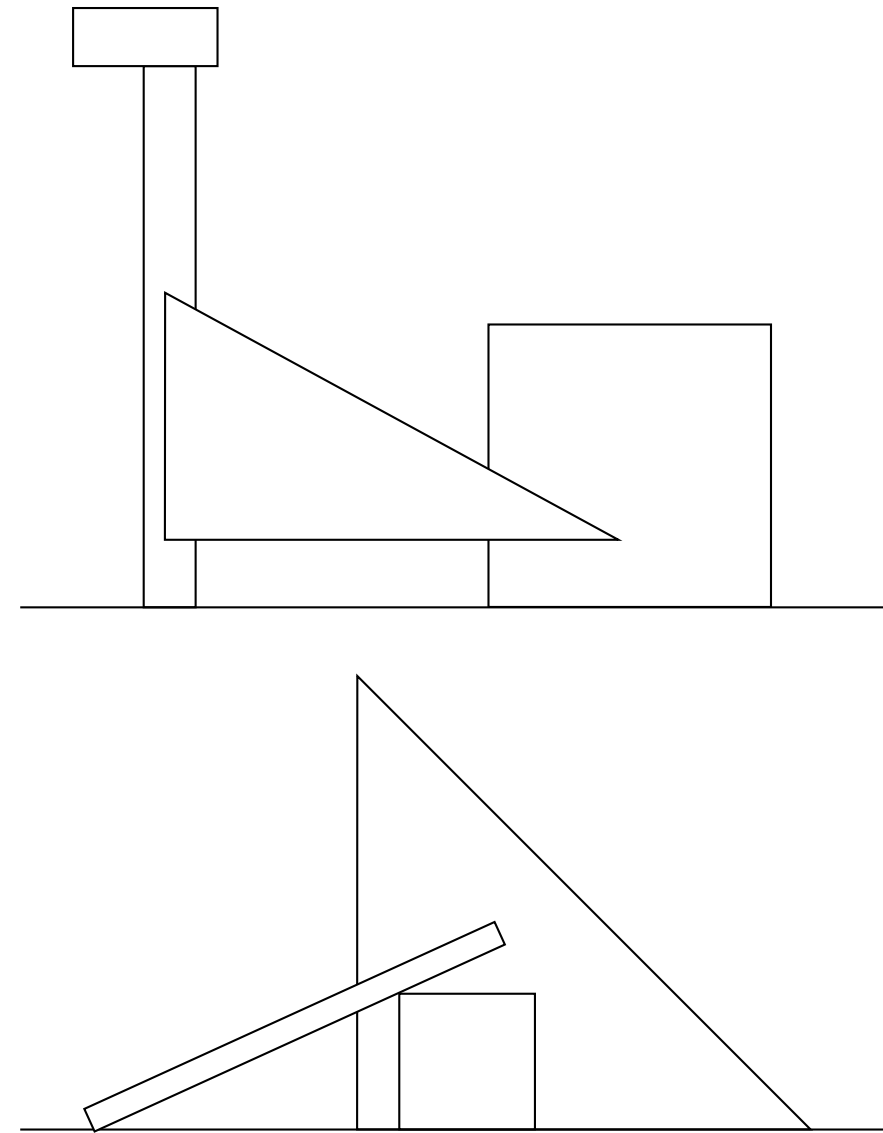
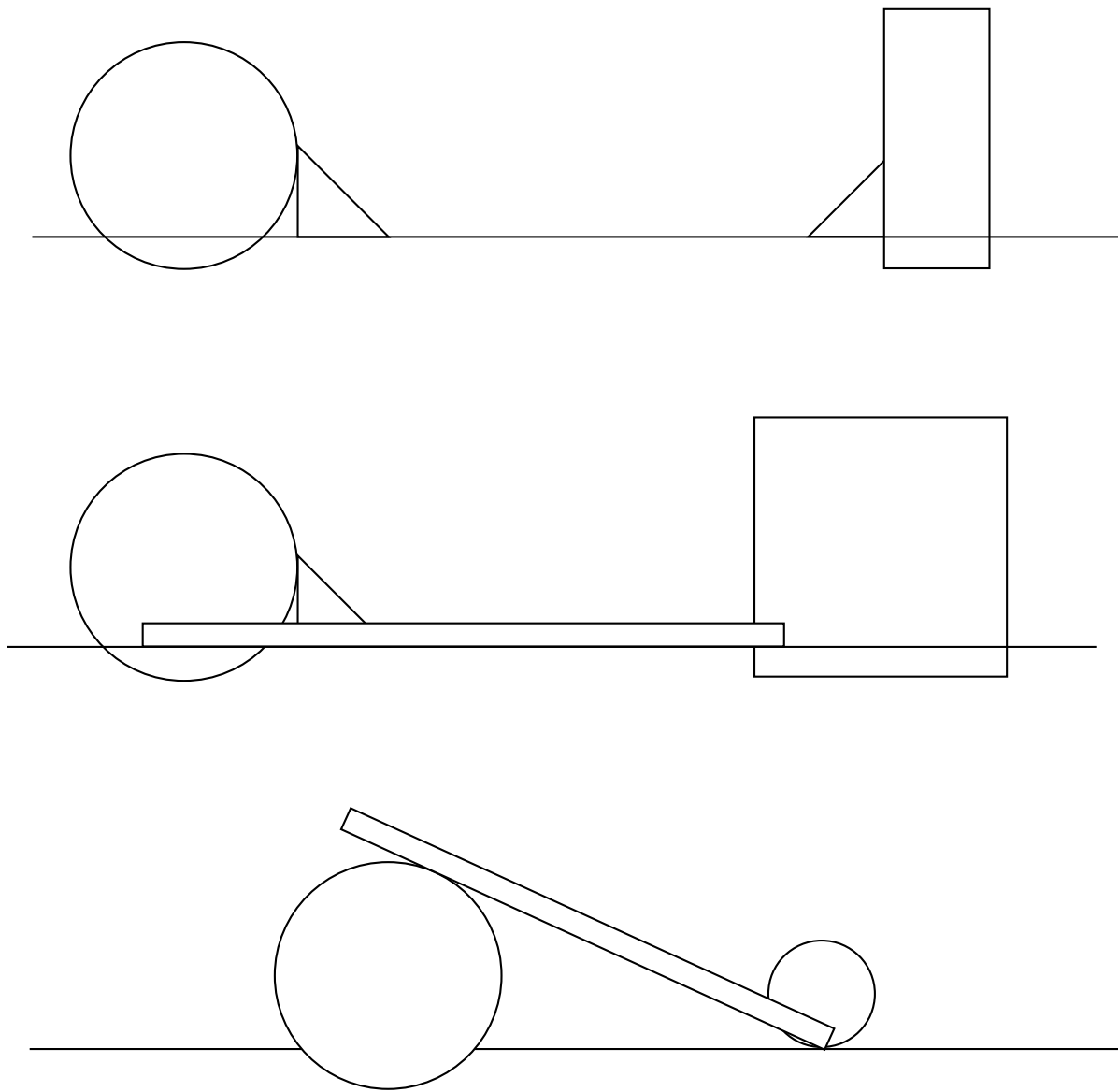

Deployment of Forms

These follies are the seeds of architectural imagination that sparks new threads of creativity within the slum.

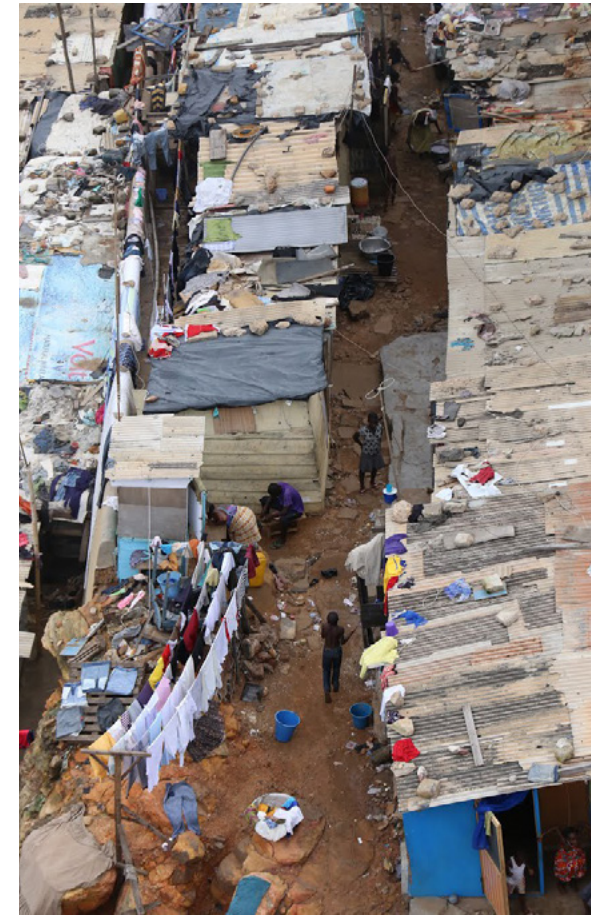

Space-making on site.



Space-making on site.



The frame is ever-present







From demolition, the materials to build anew

# 1. Base Follies

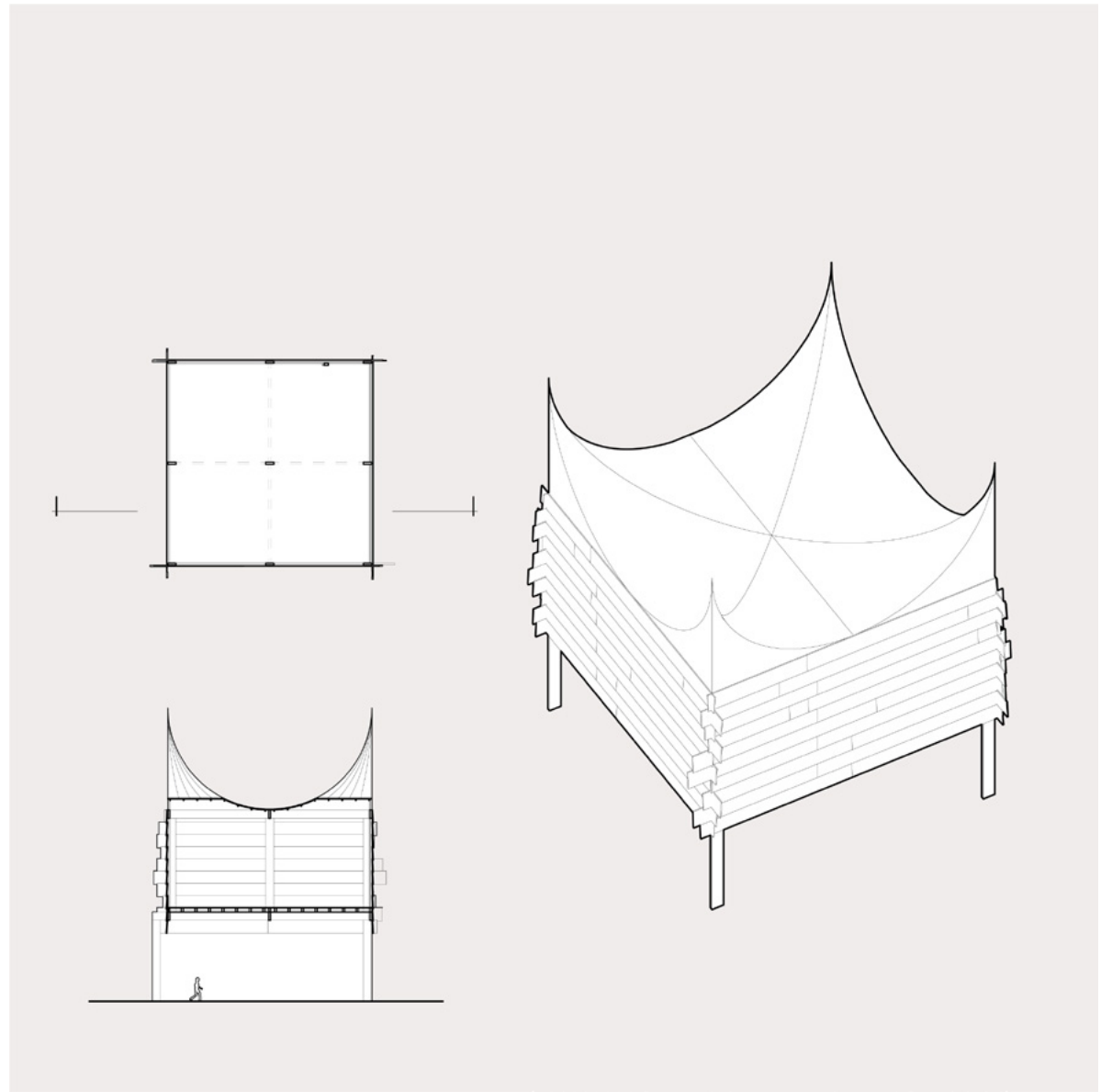

Space Module\_01

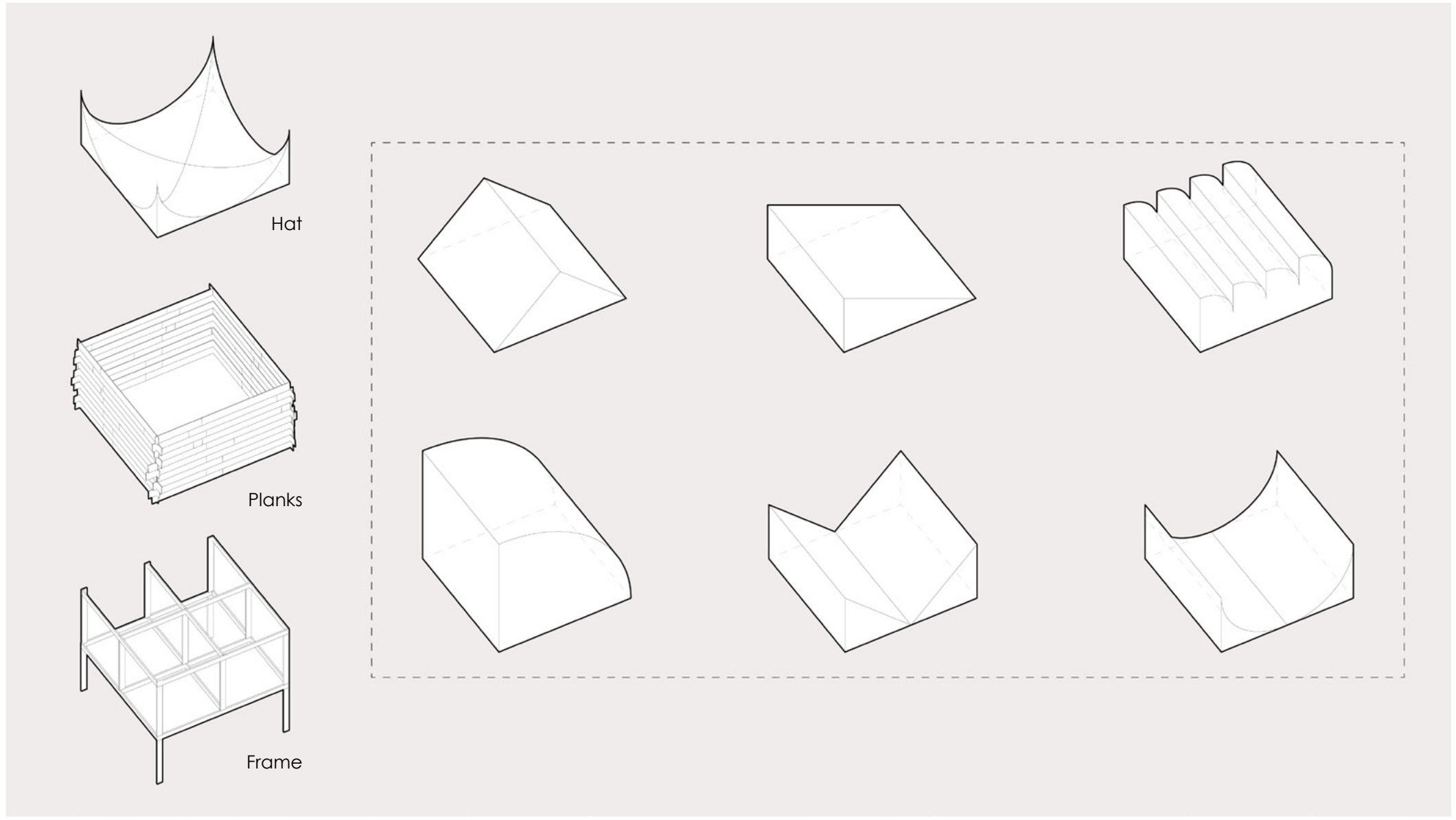

Space Module\_01 with Different Hats

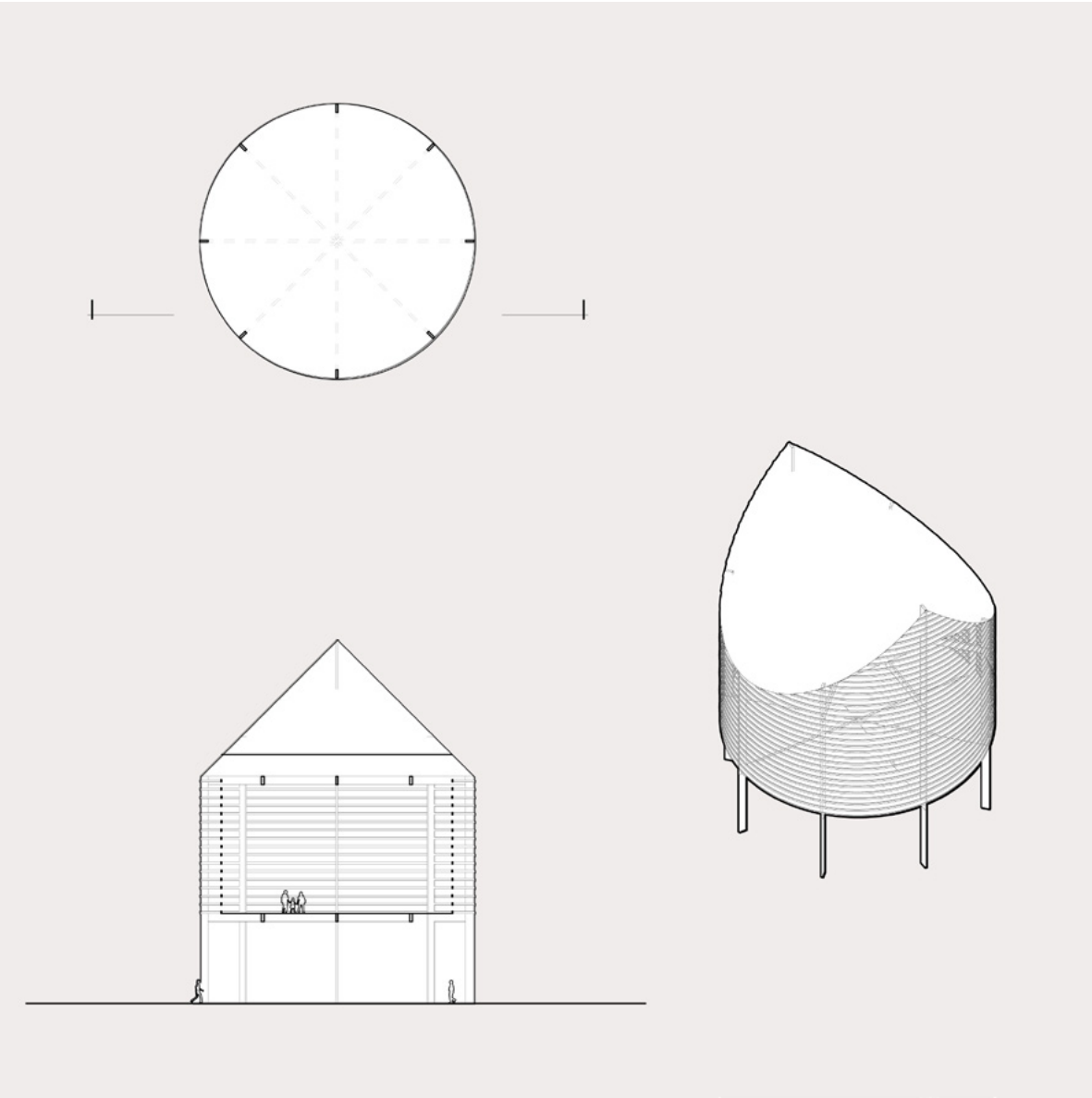

Space Module\_02

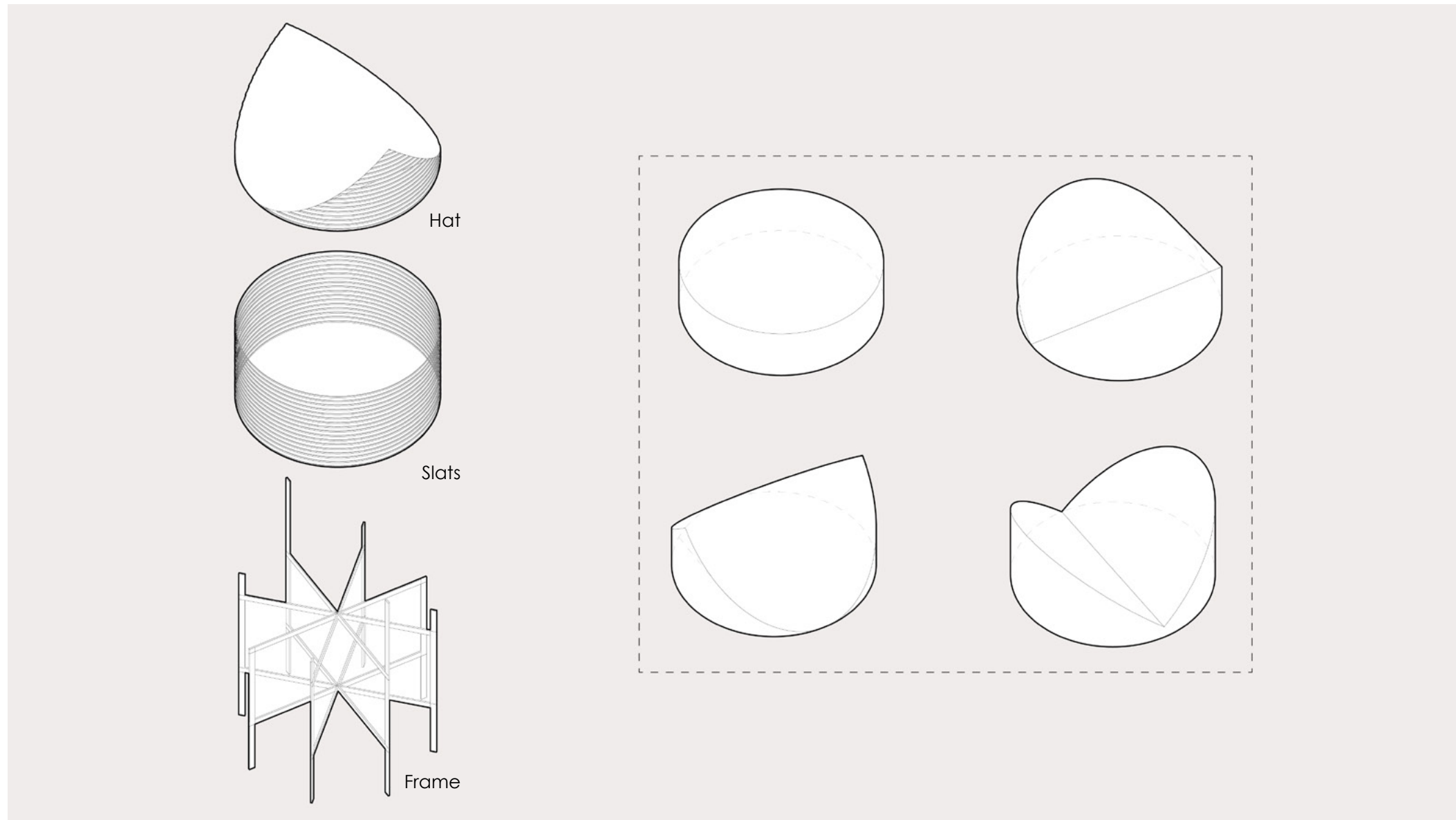

Space Module\_02 with Different Hats

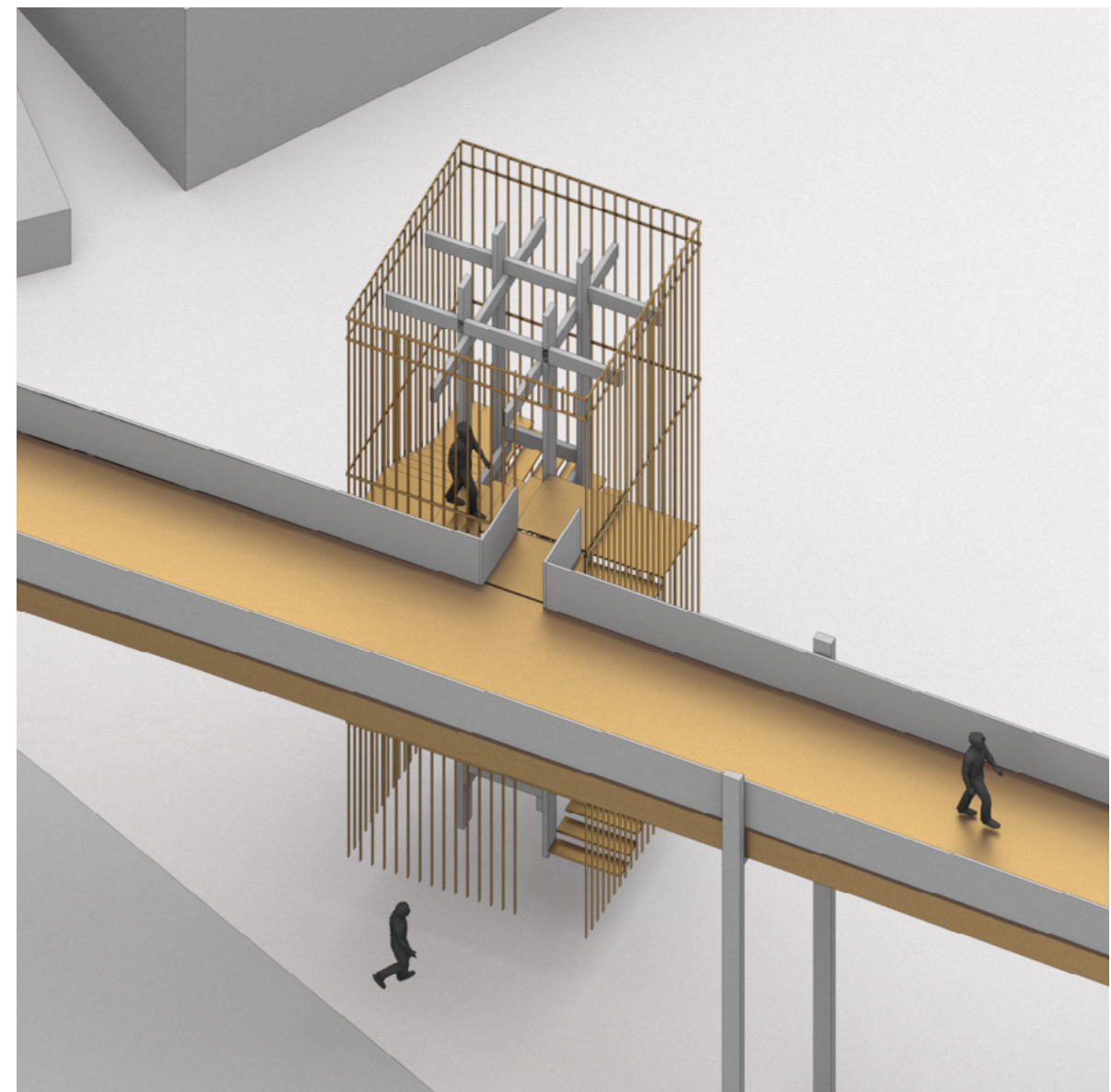
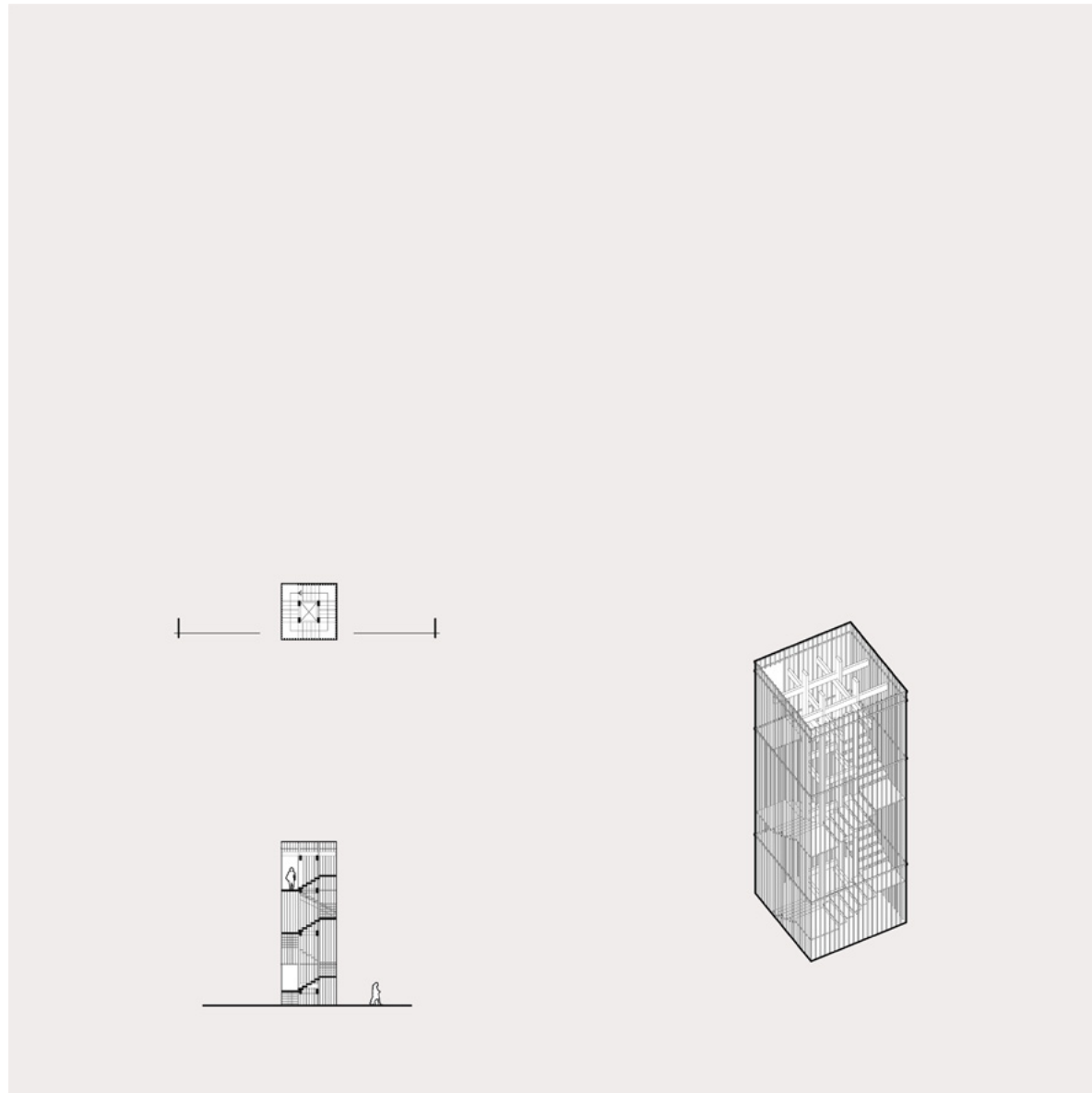

Circulation Module\_01



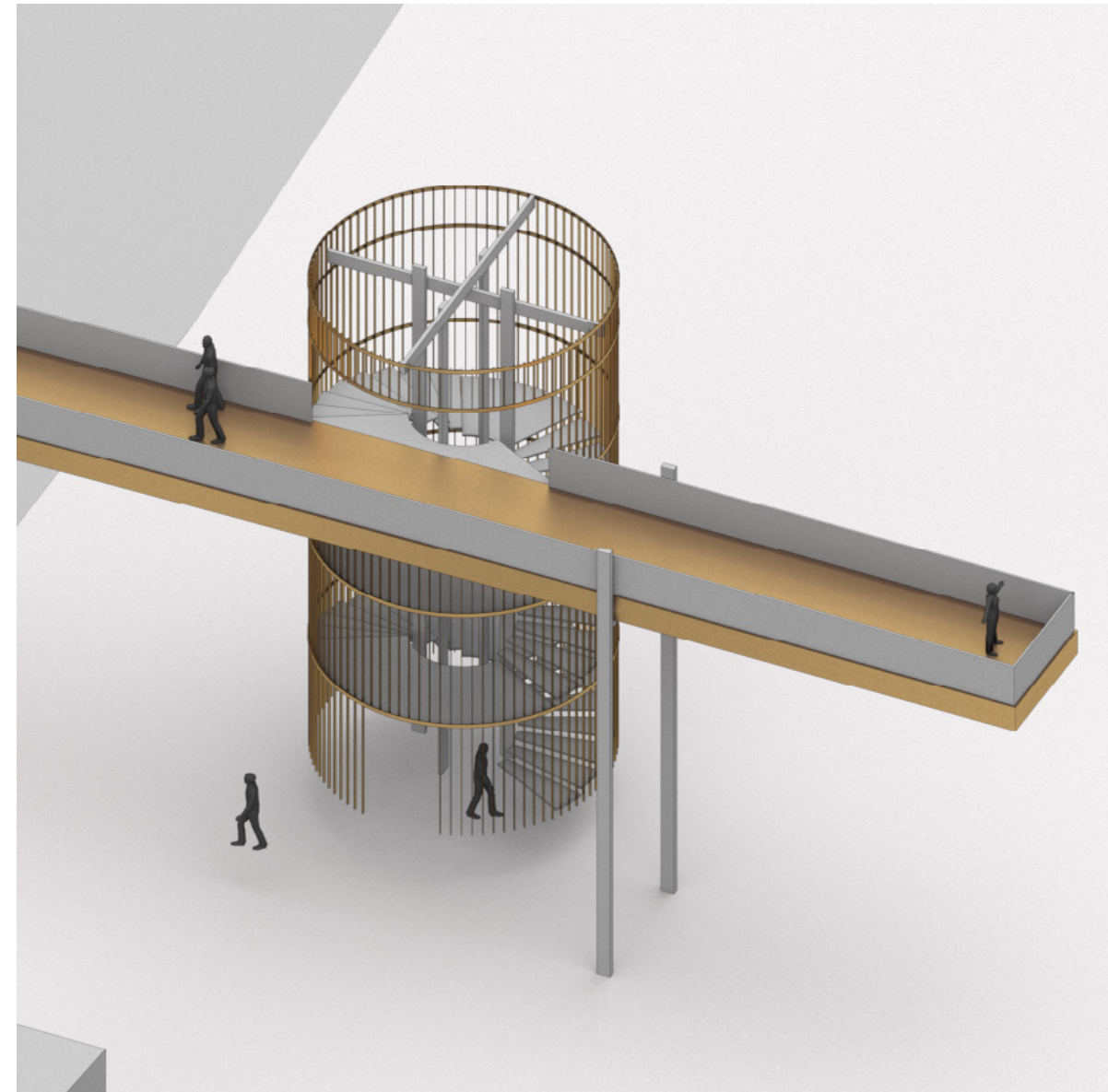
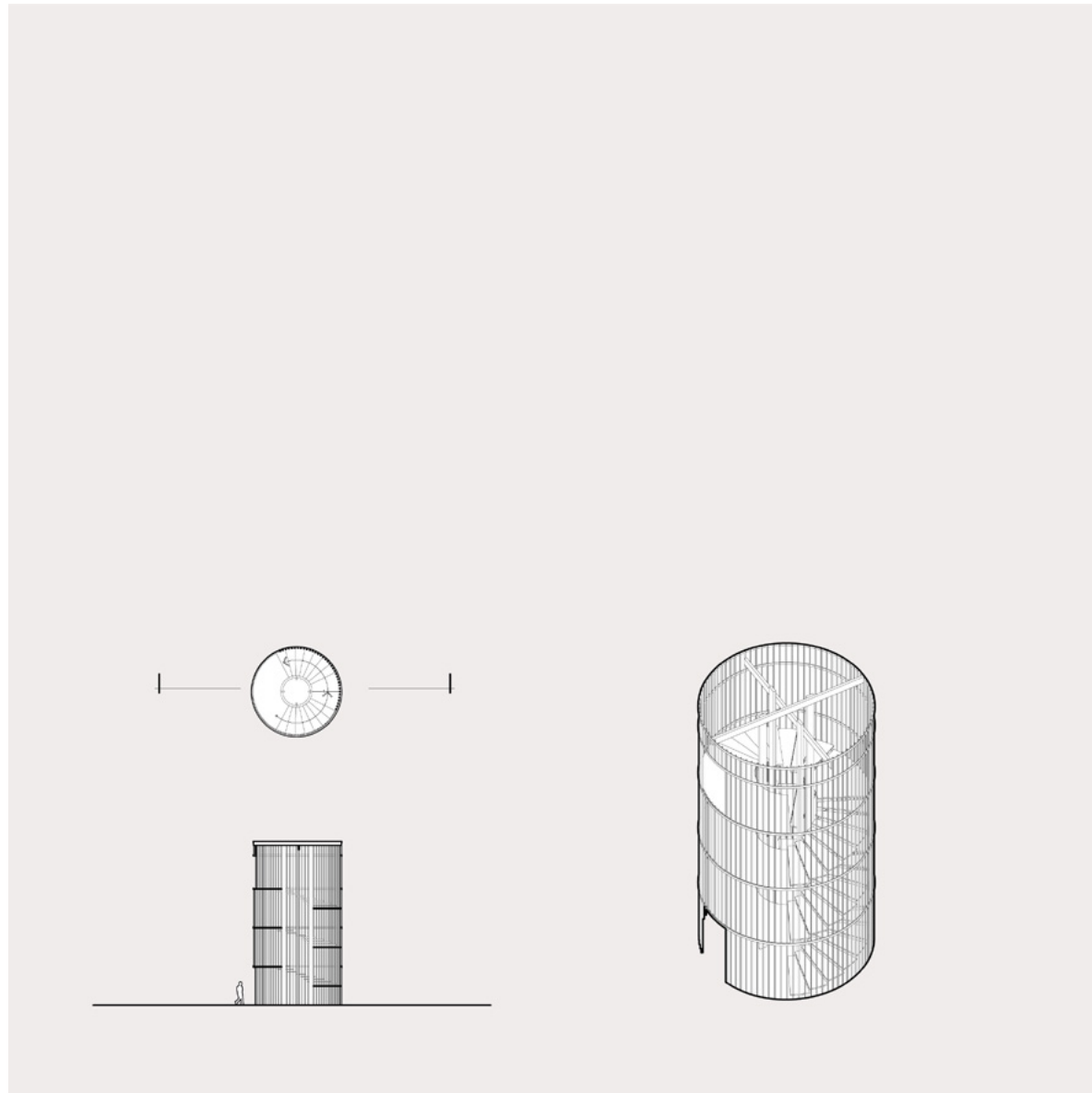

Circulation Module\_02

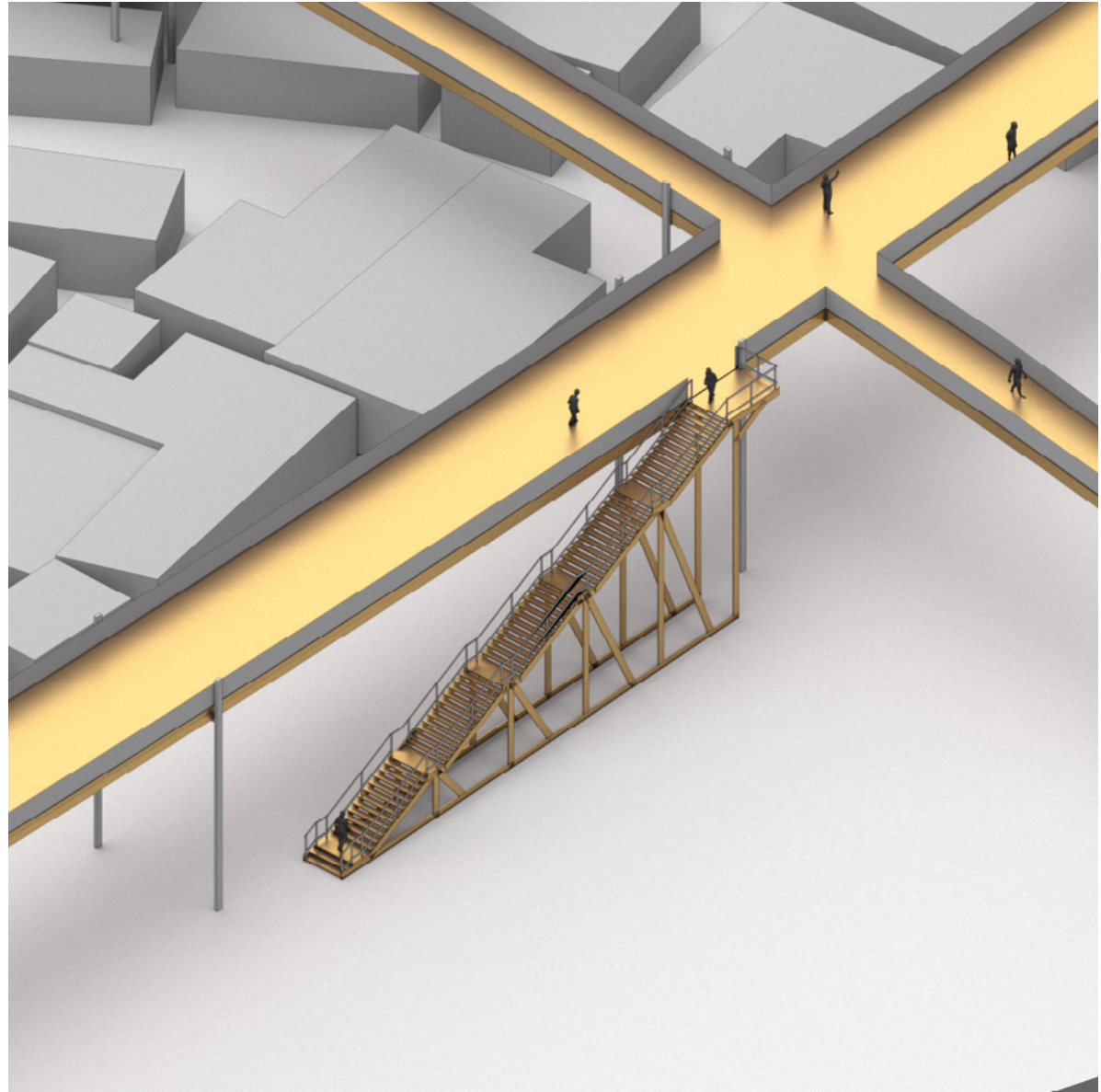
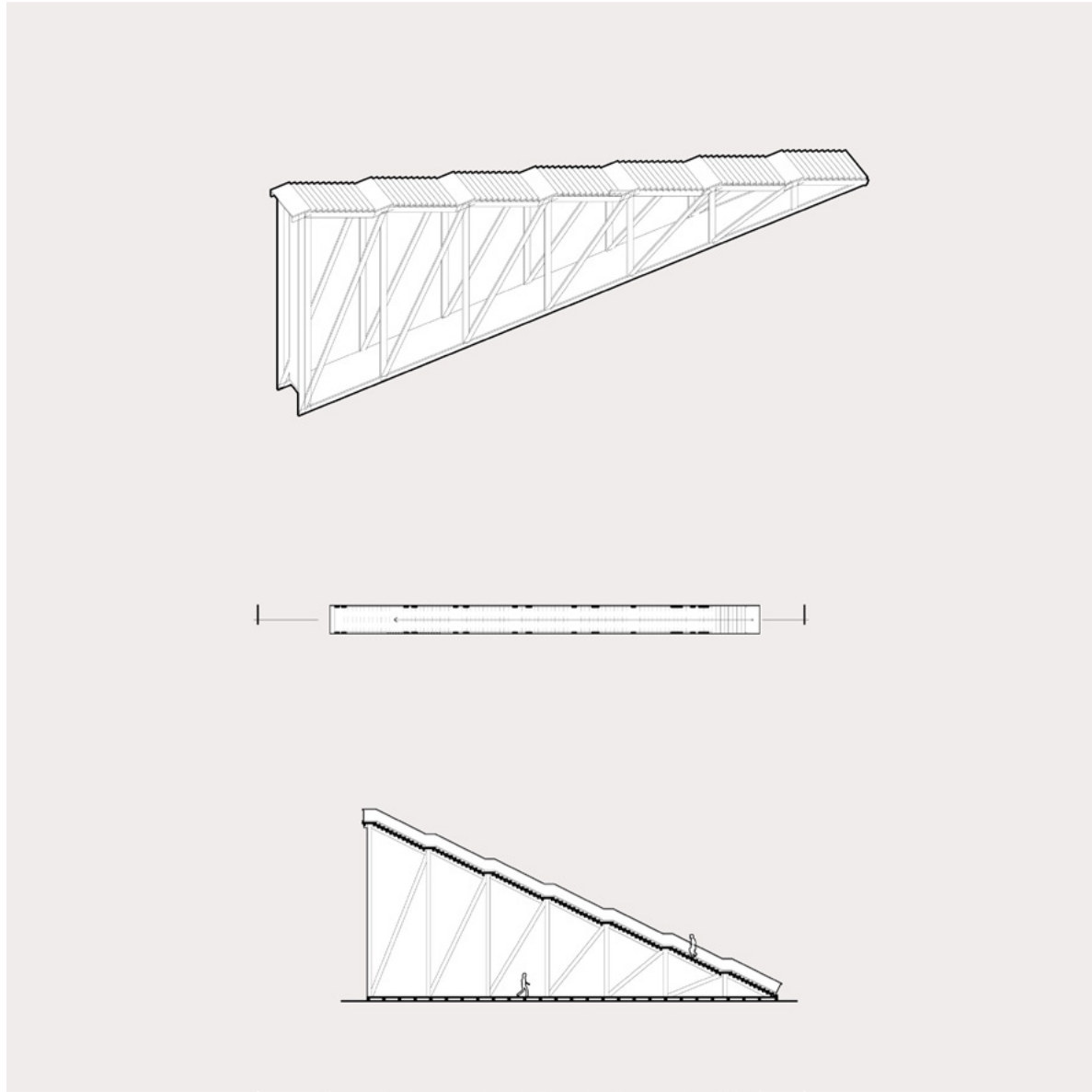

Circulation Module\_03

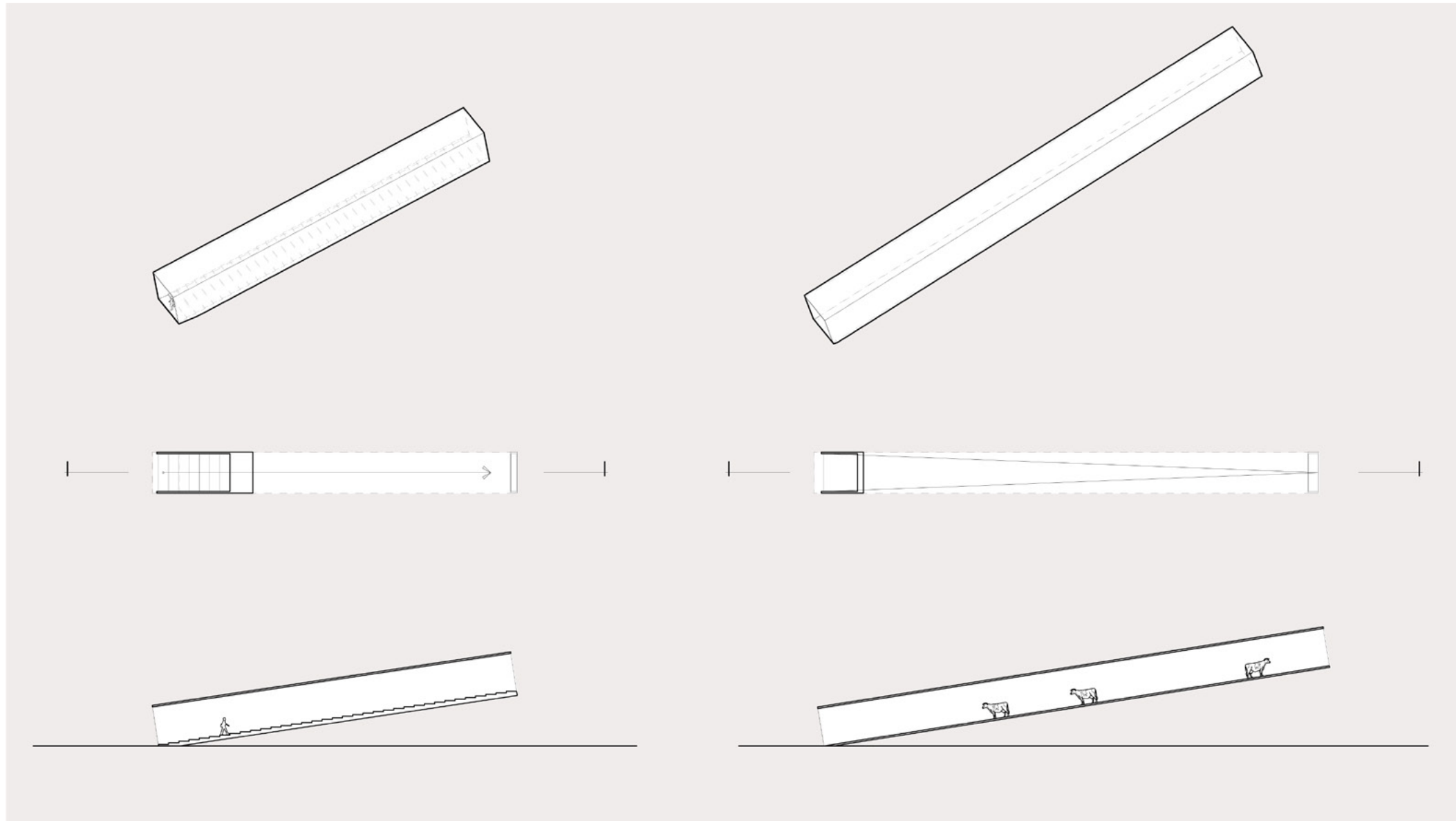

Circulation Module\_04 and 05

## 2. From Follies to Architecture

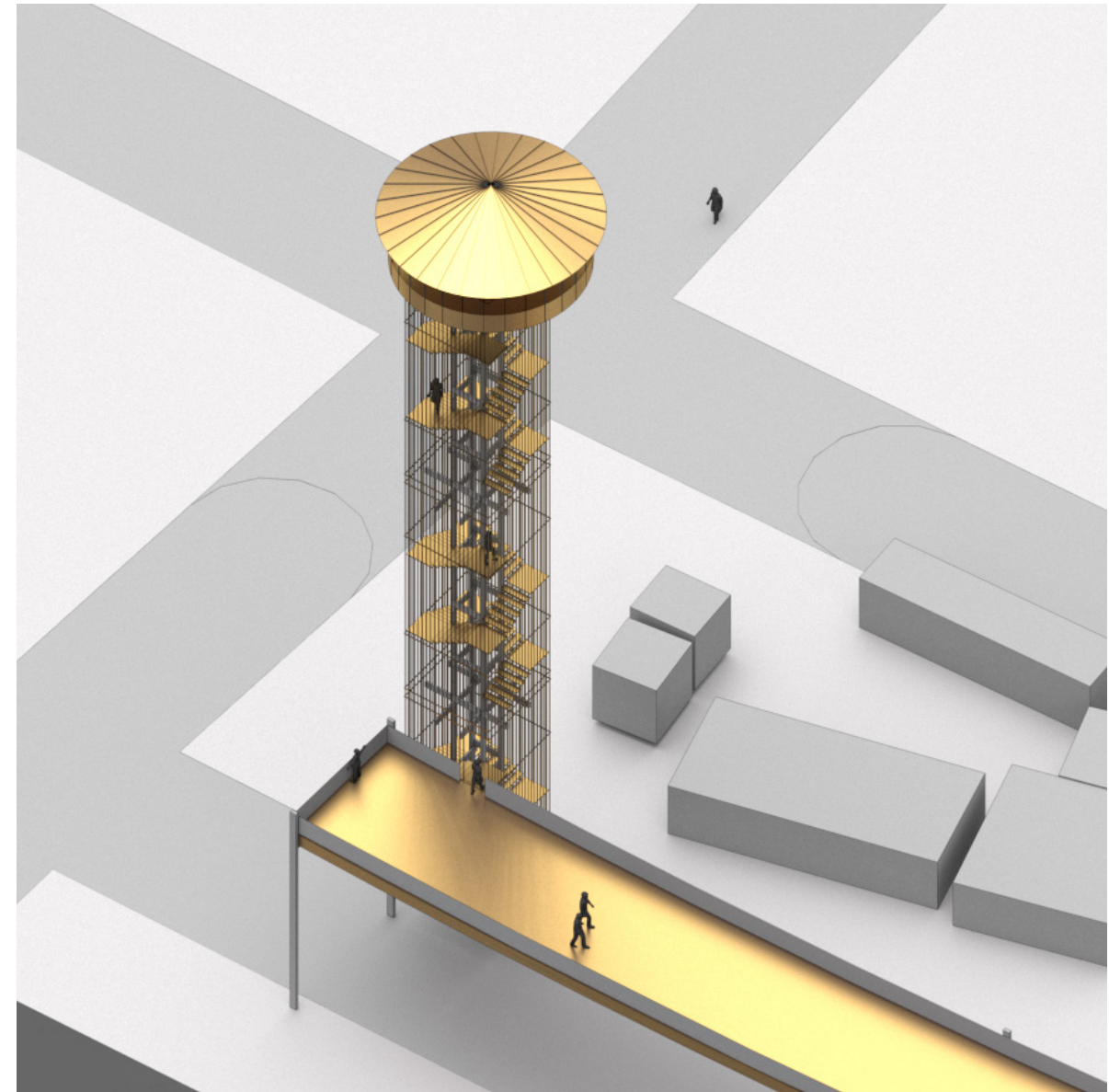
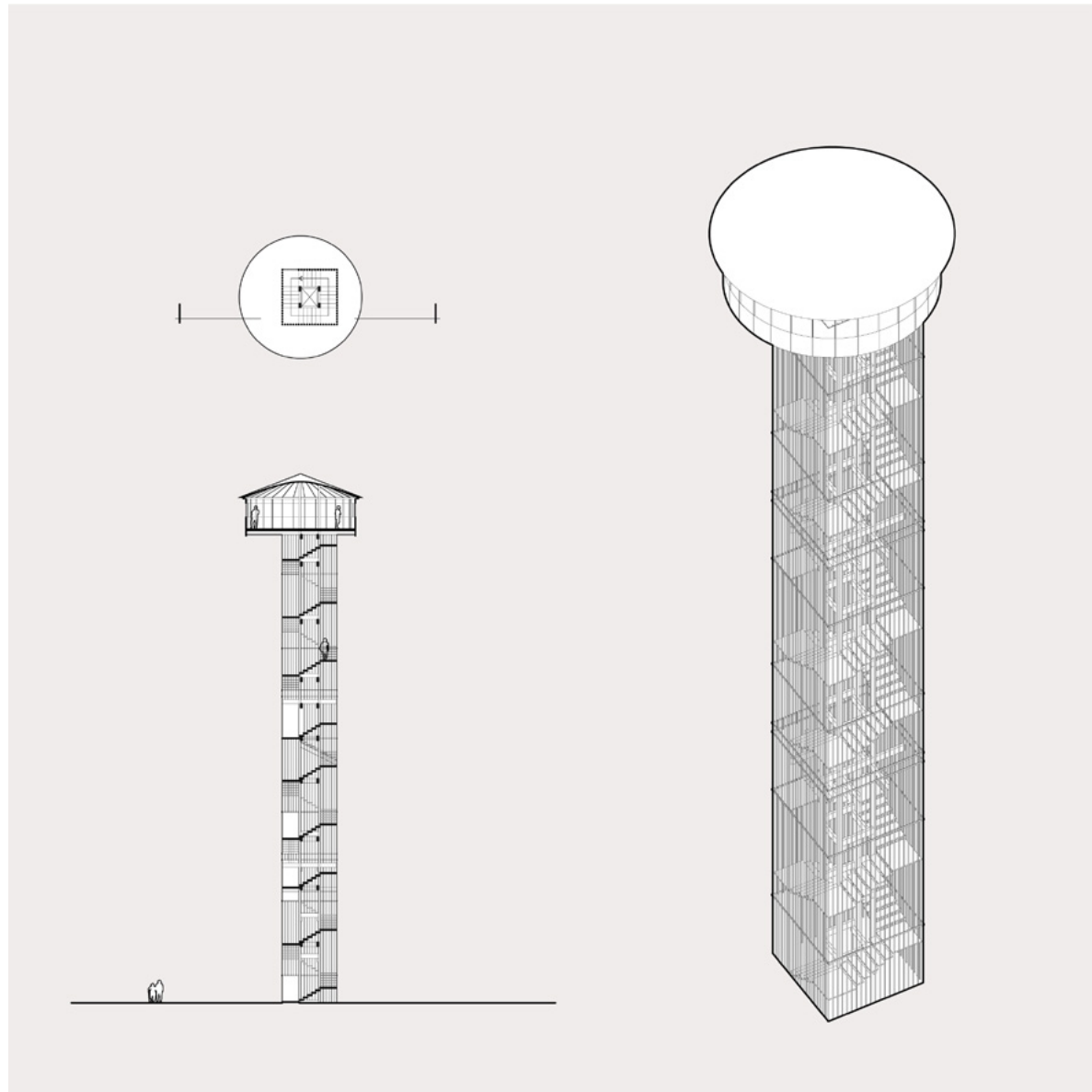

'Watchman's Tower'

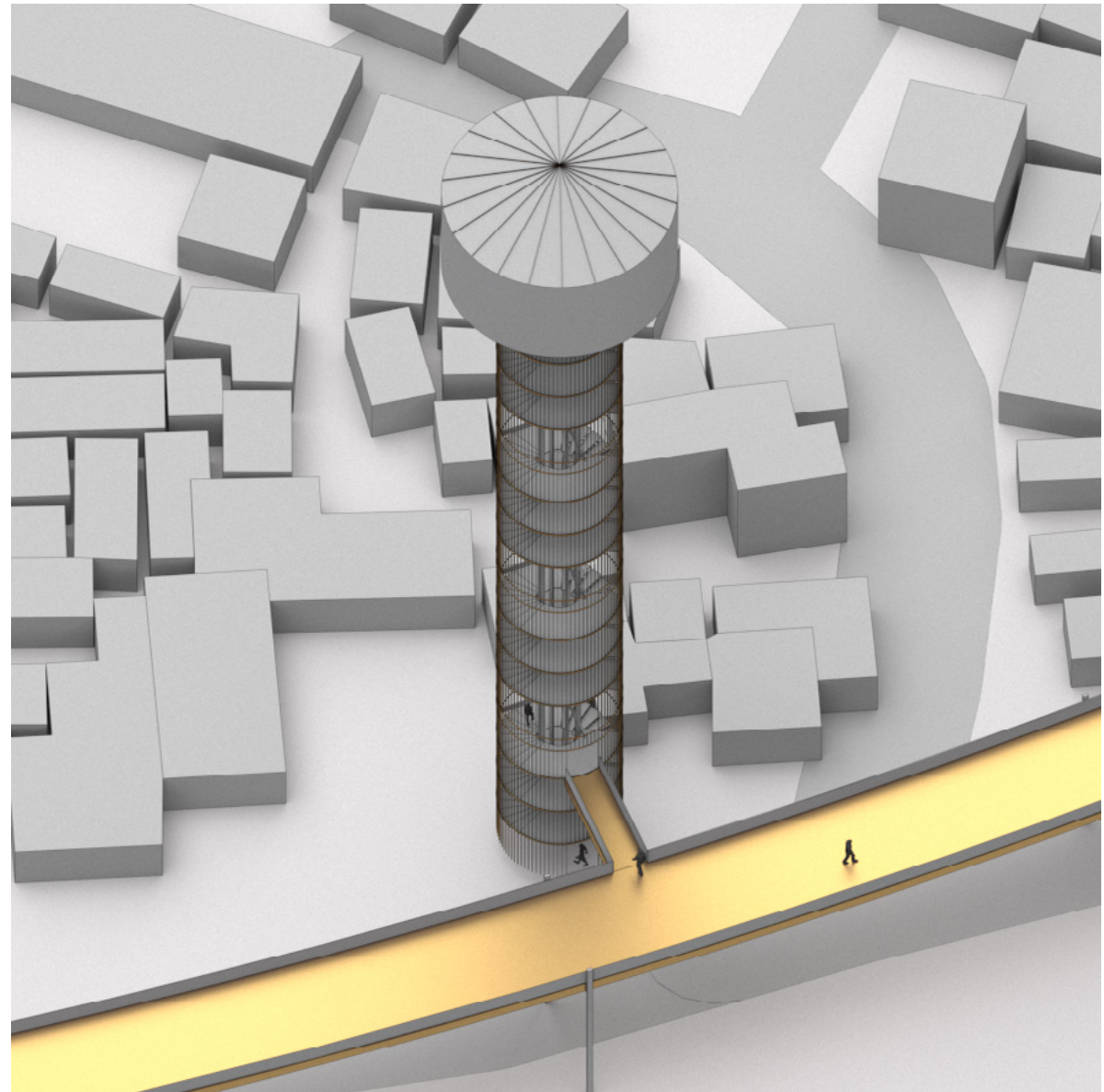
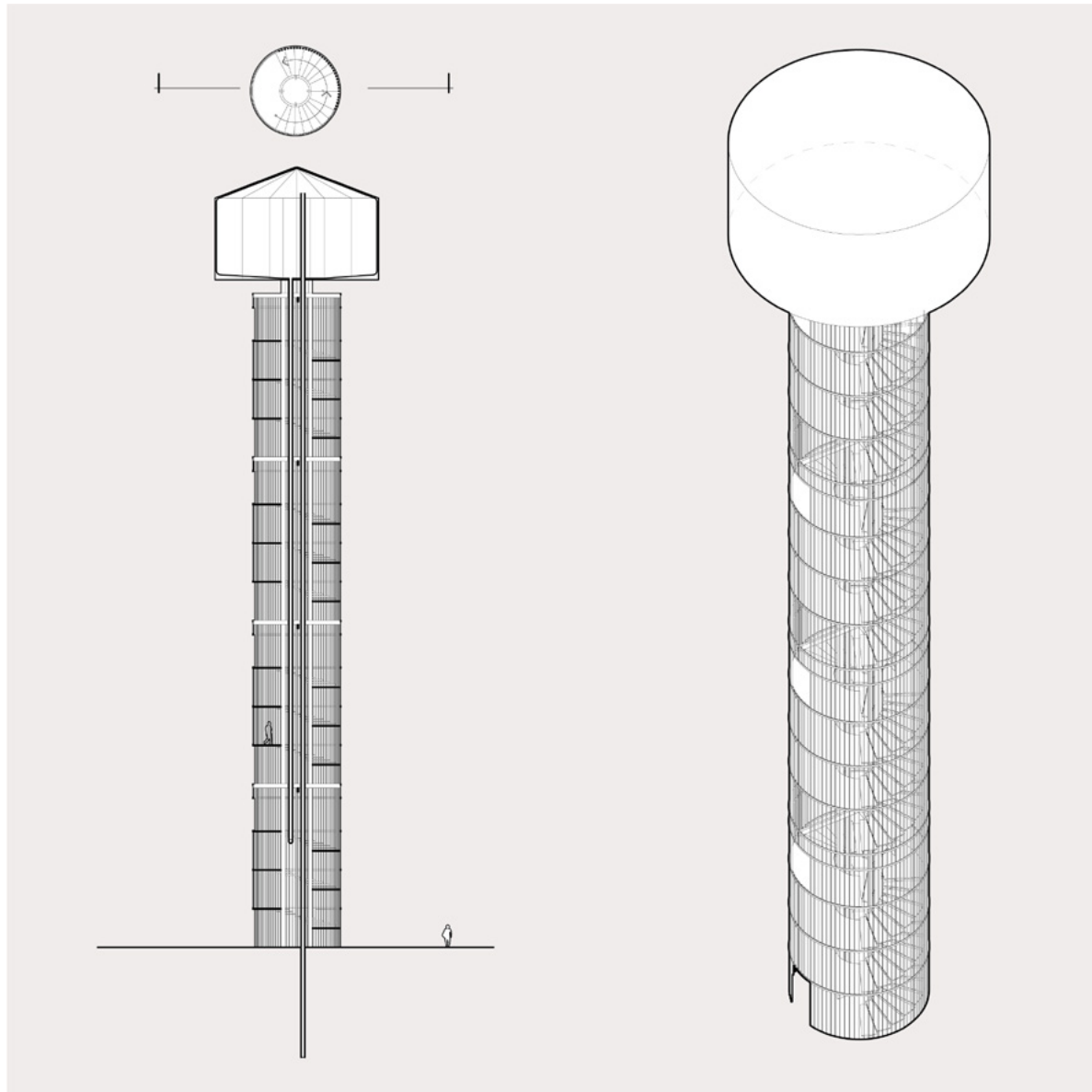

'The Well'

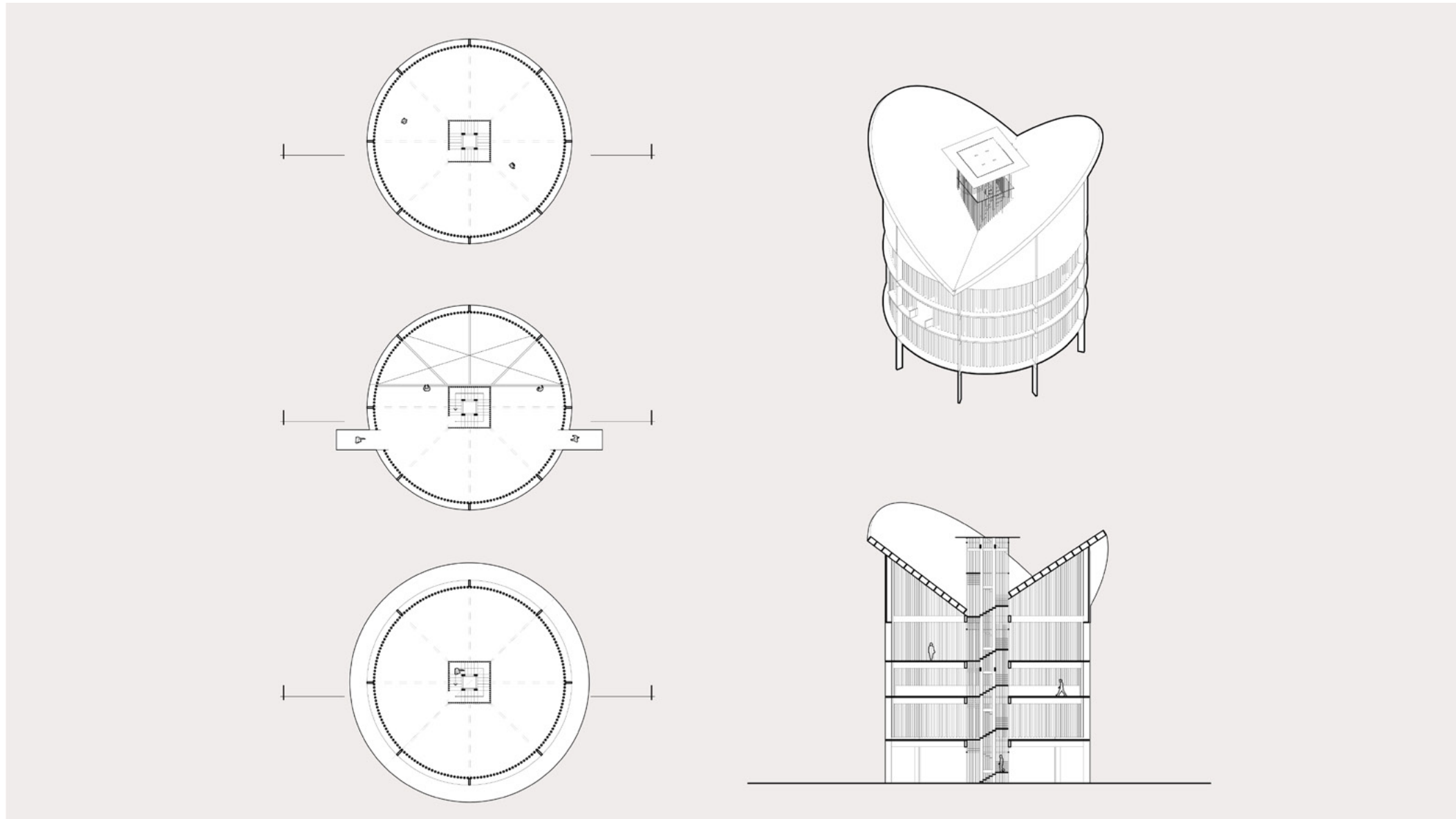

'The Mallam's House'

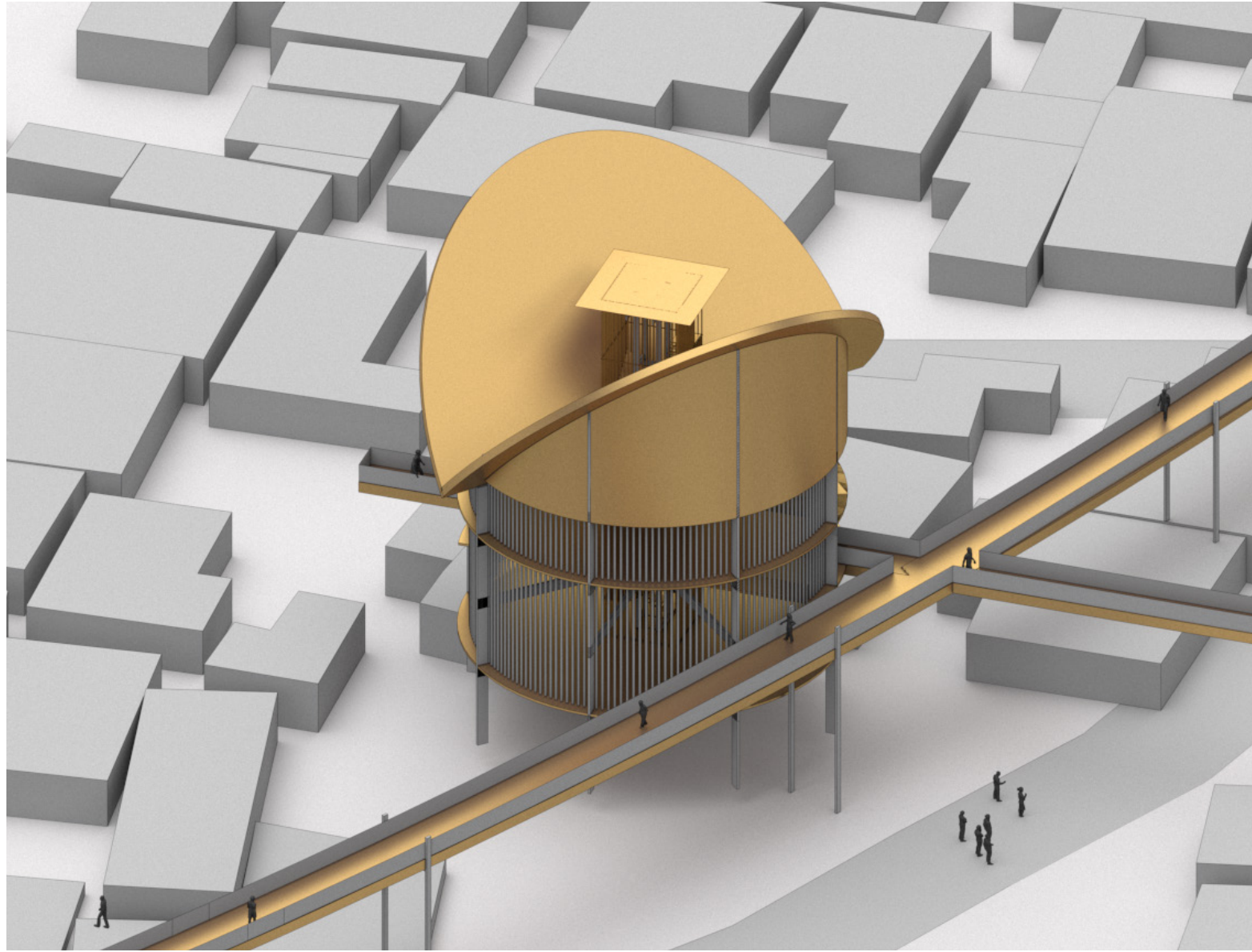

'The Mallam's House'



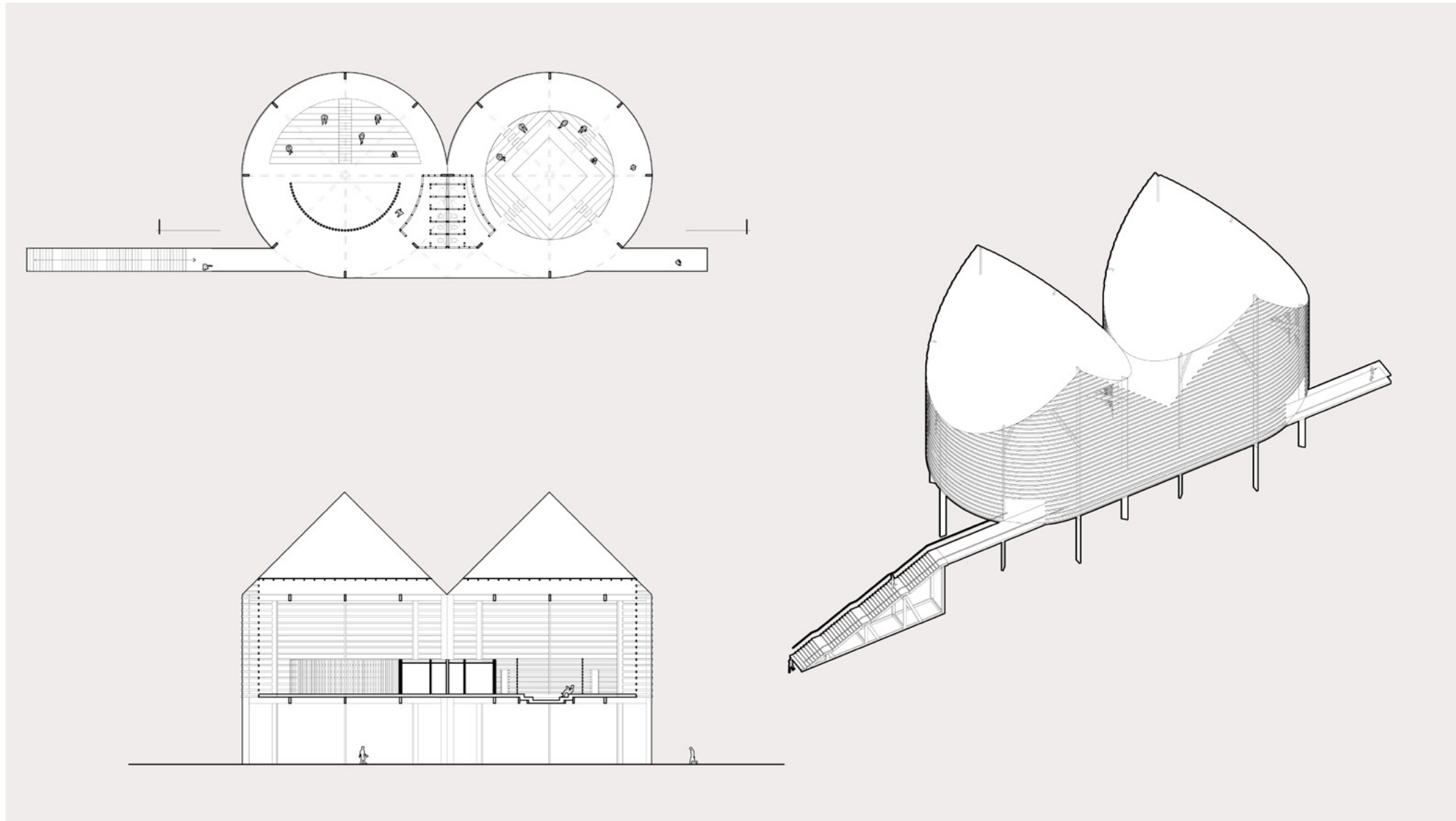

'Public Theater'

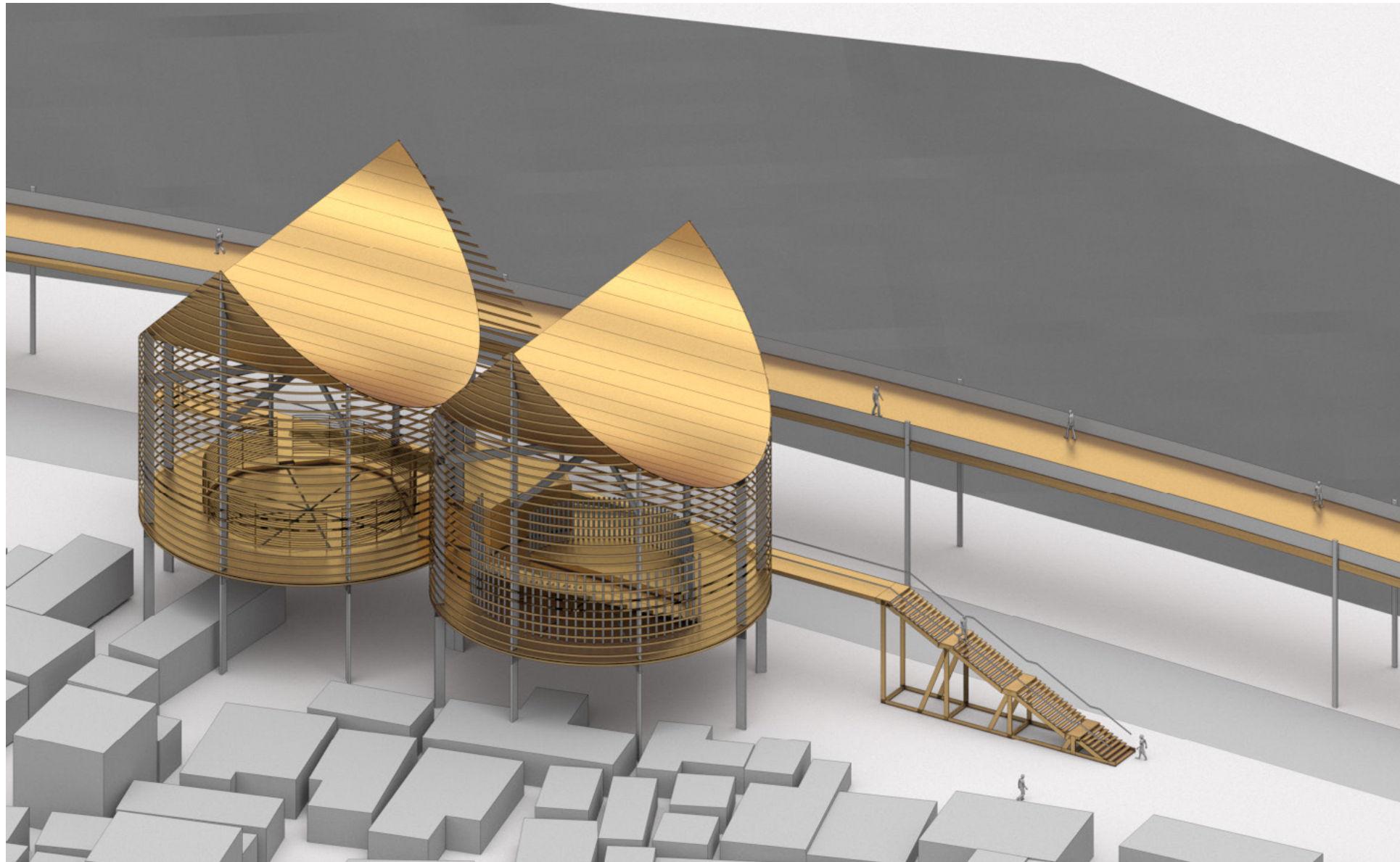

'Public Theater'

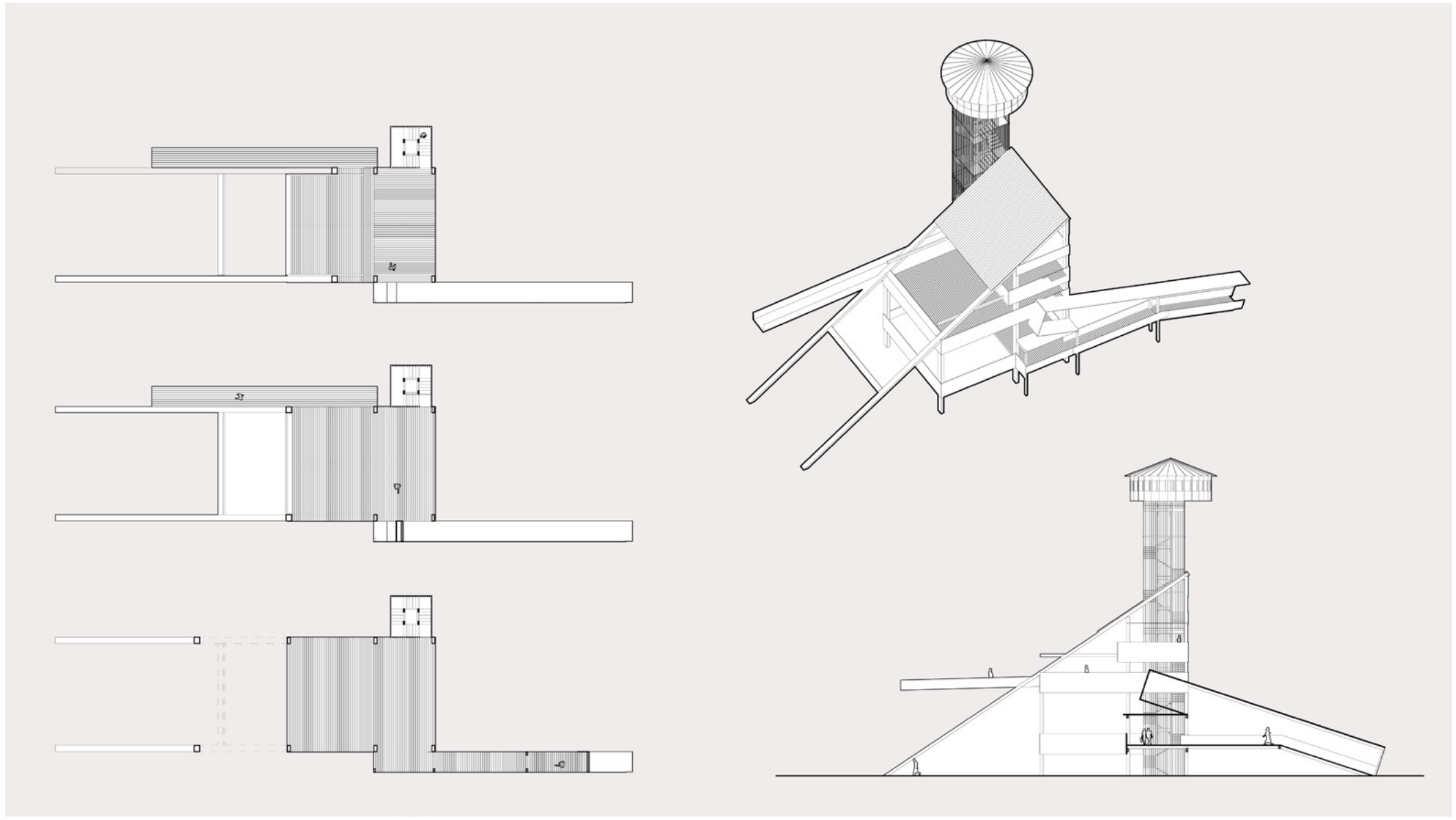

'Meeting House'

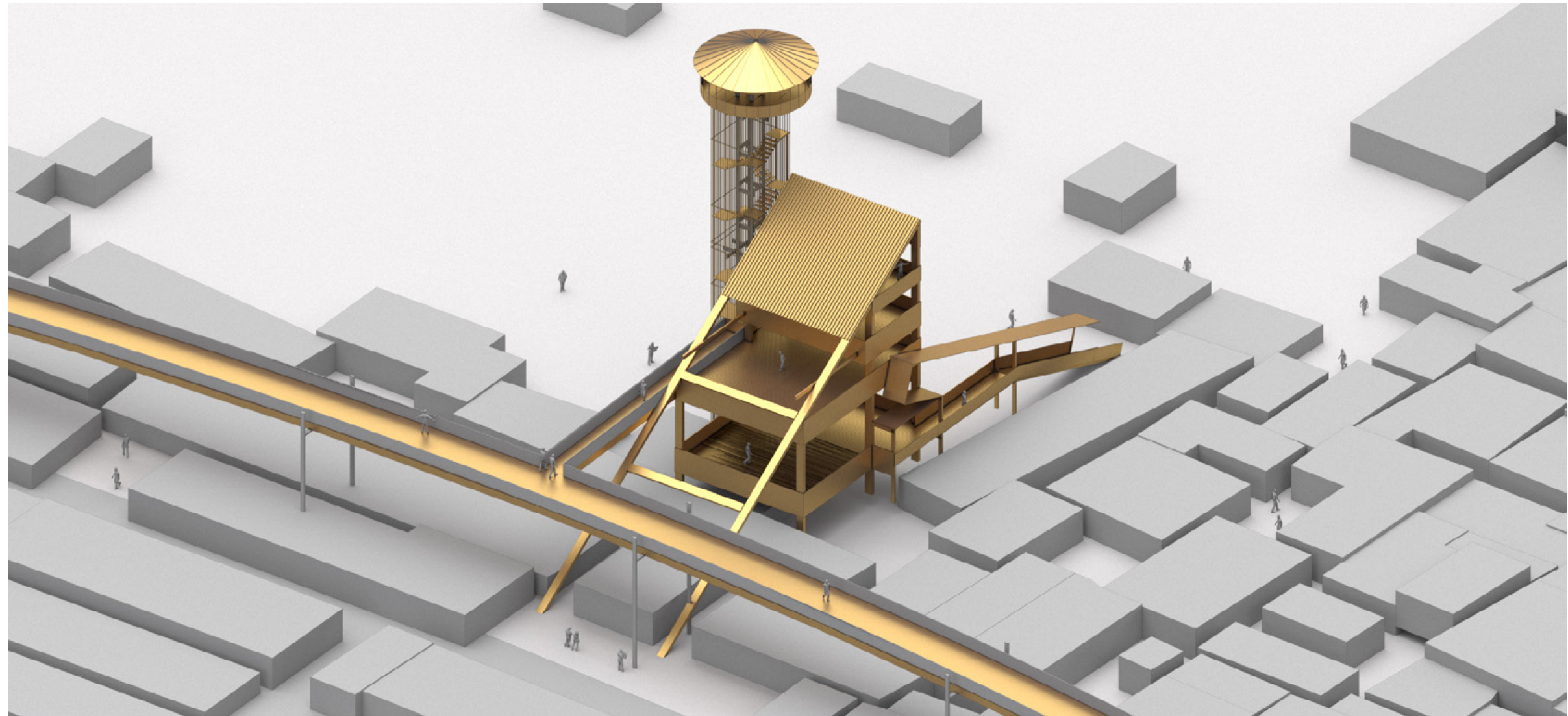

'Meeting House'

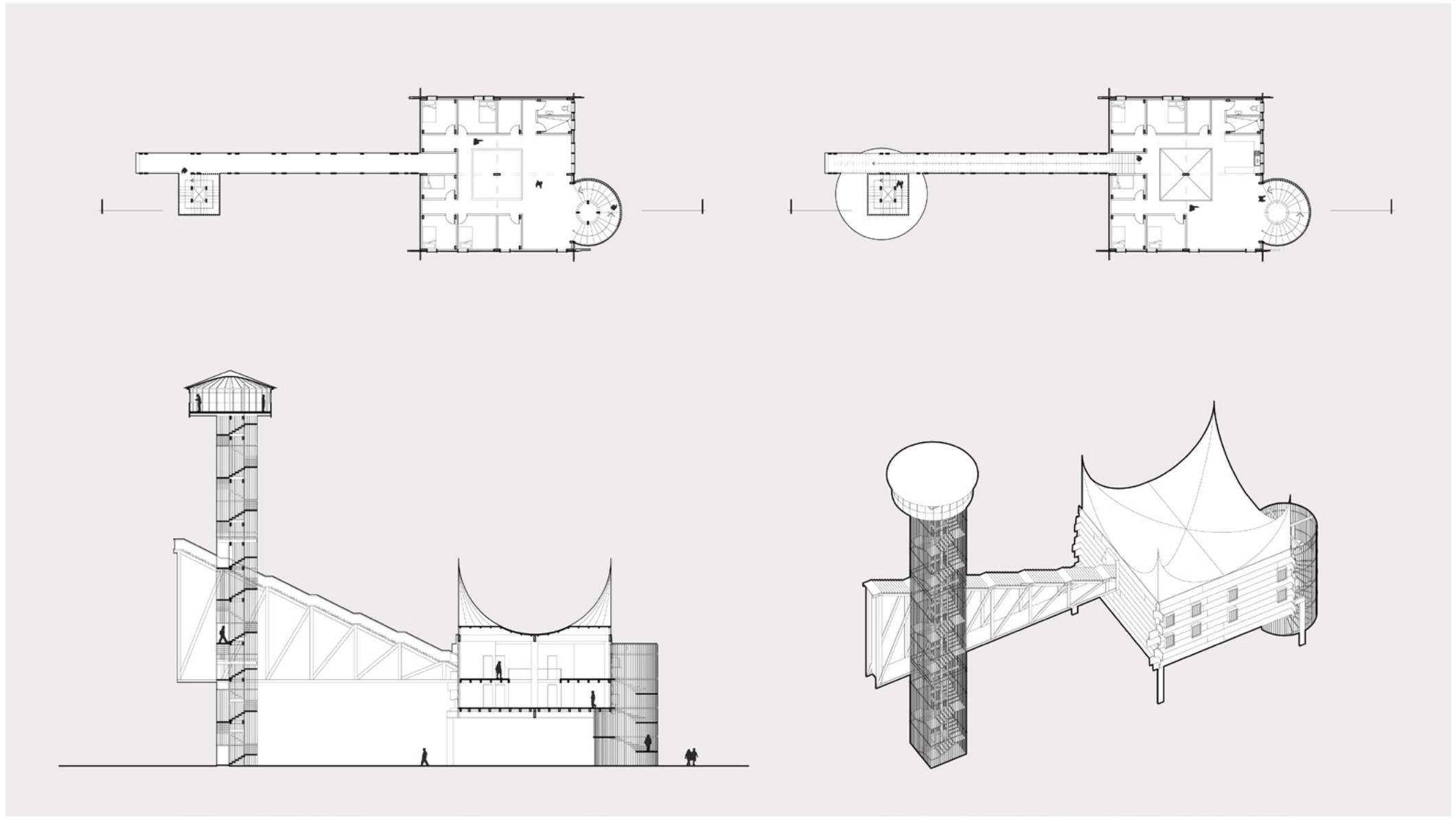

'Warchief's House'

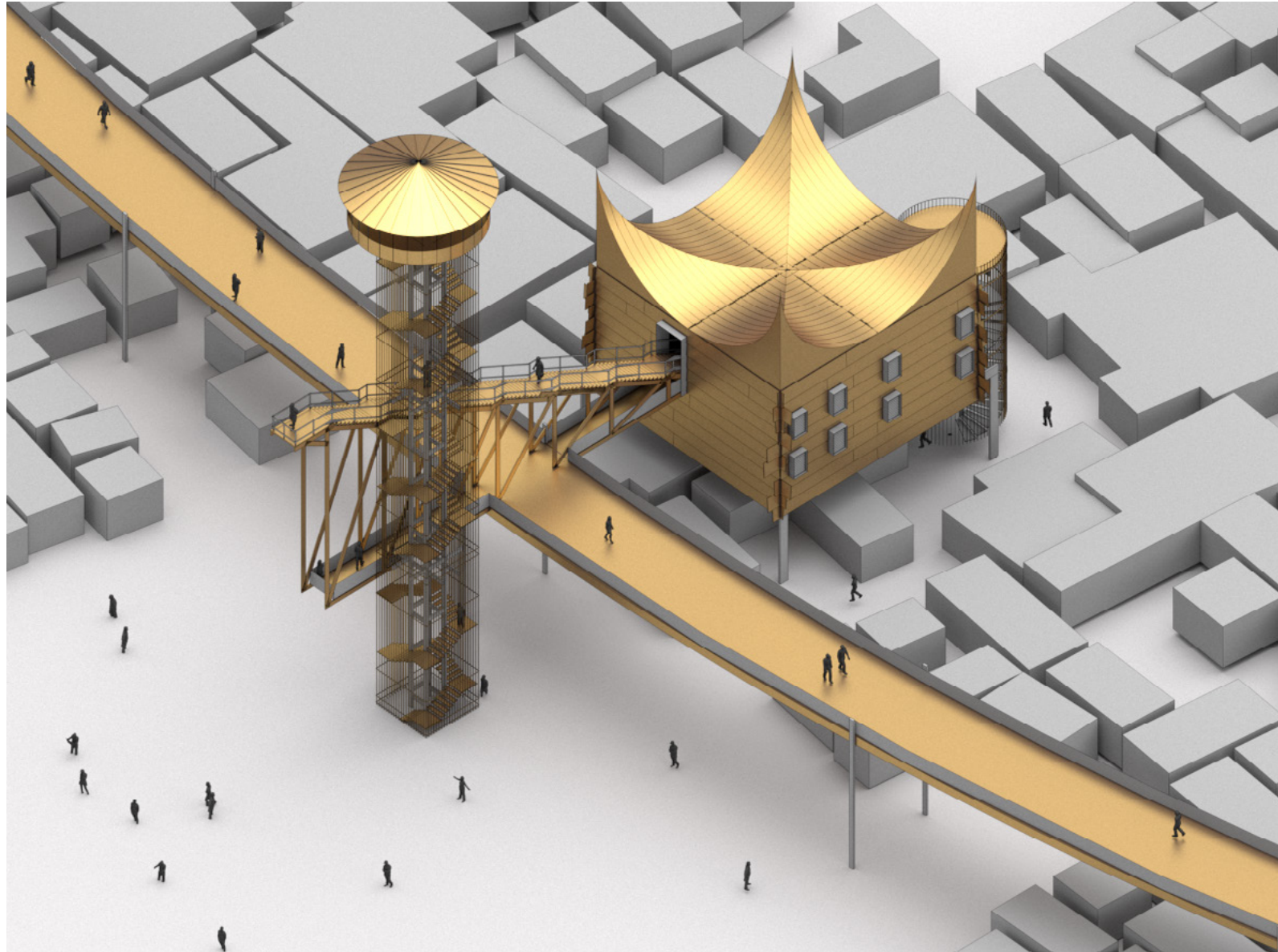

'Warchief's House'

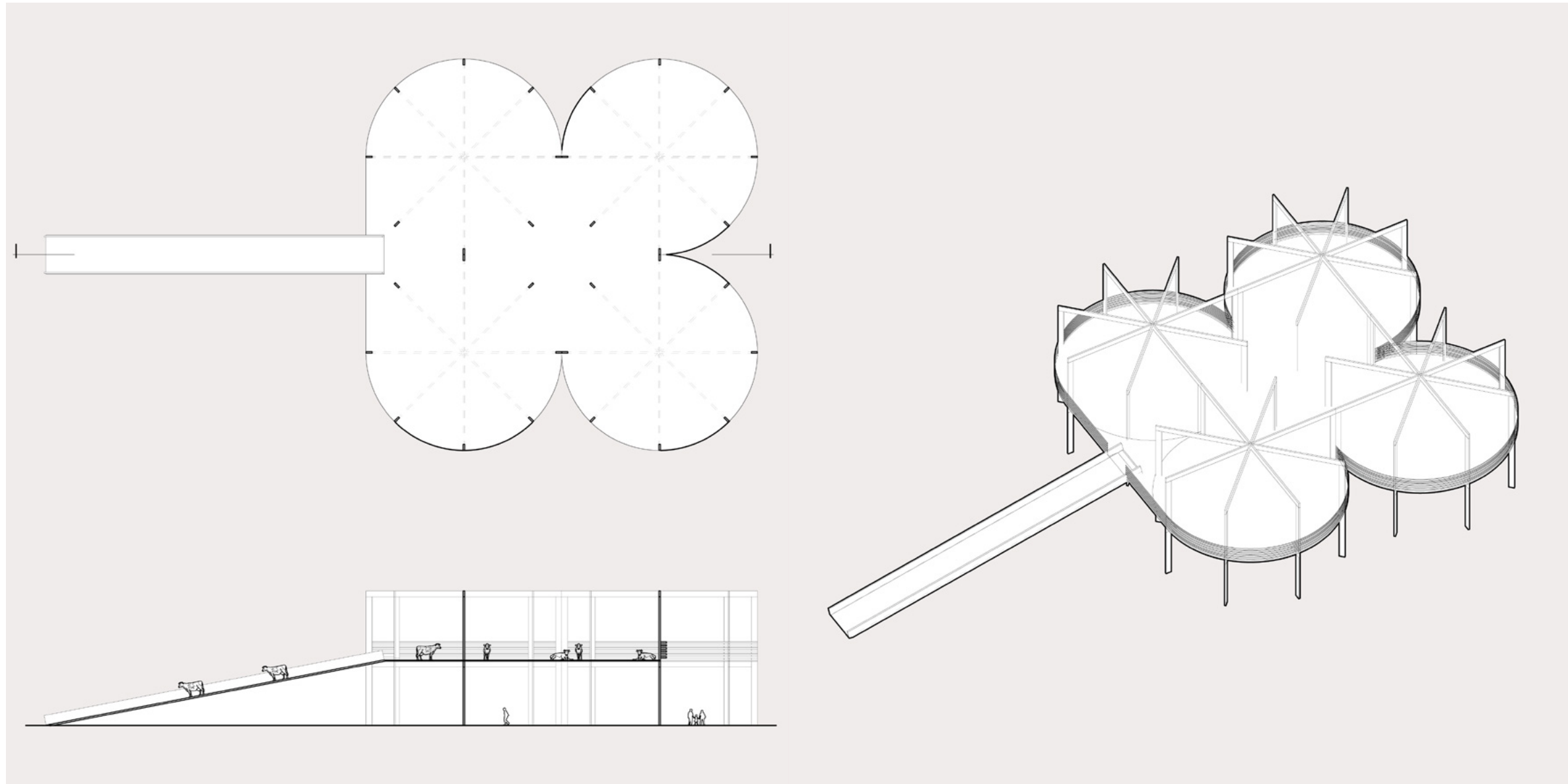

'Pasture'

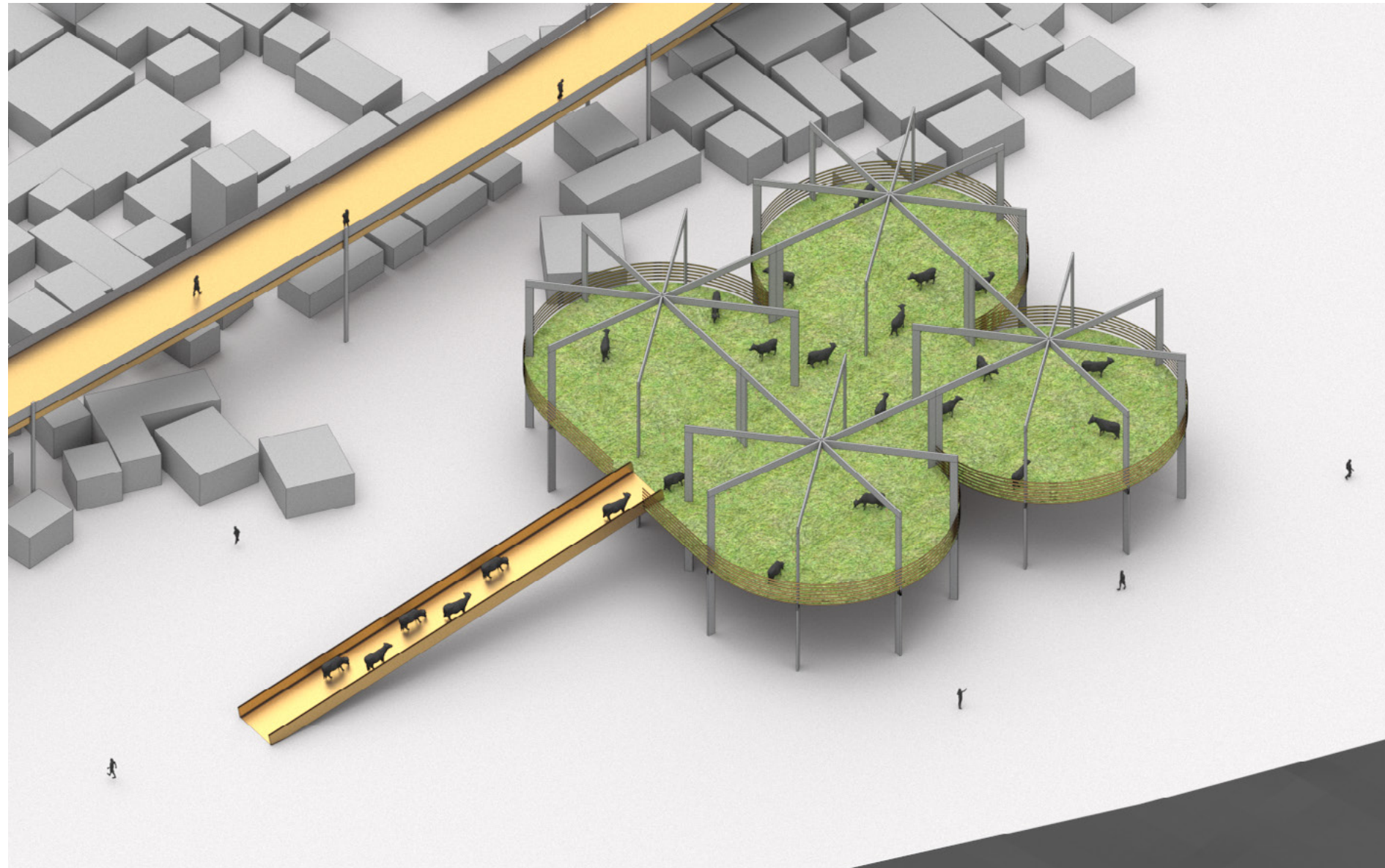

'Pasture'



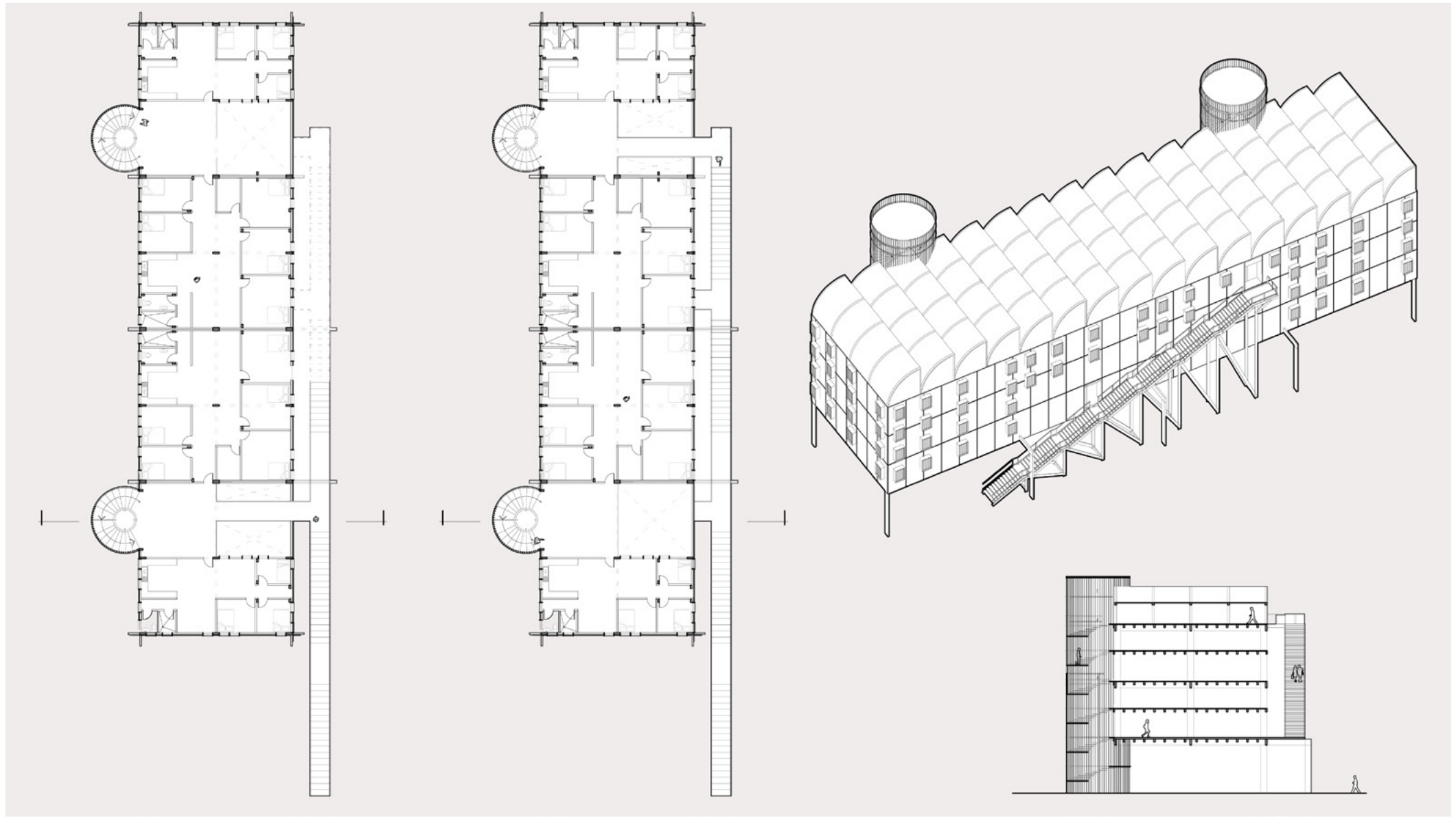

'House for Commoners'



'House for Commoners'

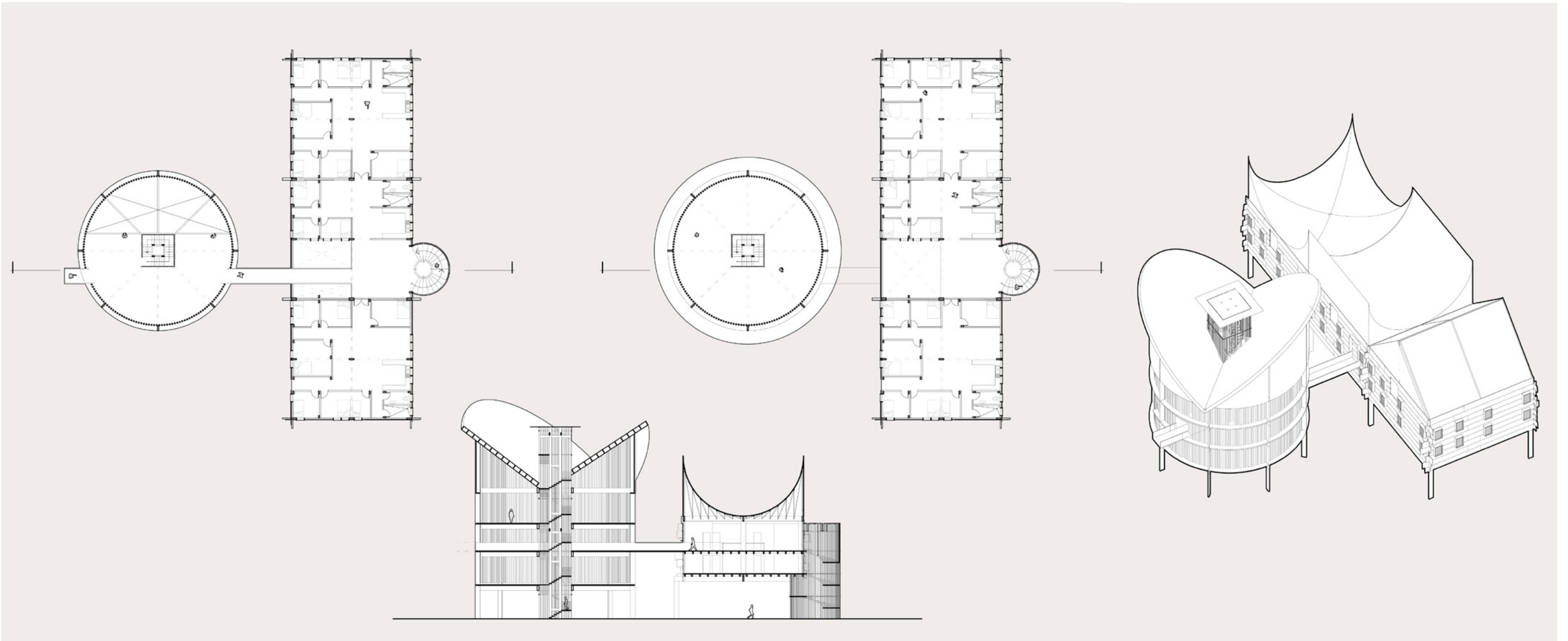

'Royal House'

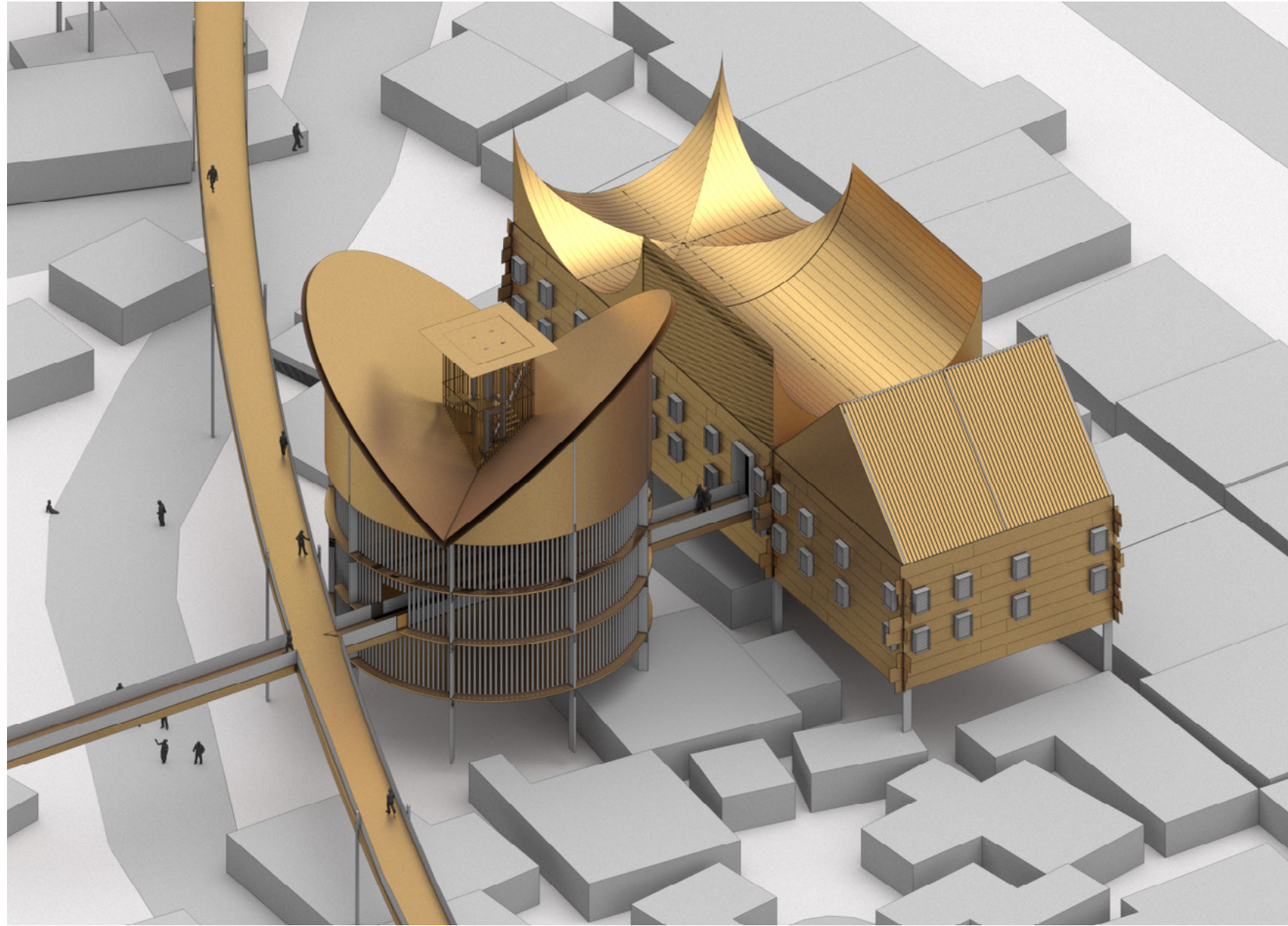

'Royal House'

### 3. From Architecture to Urbanism

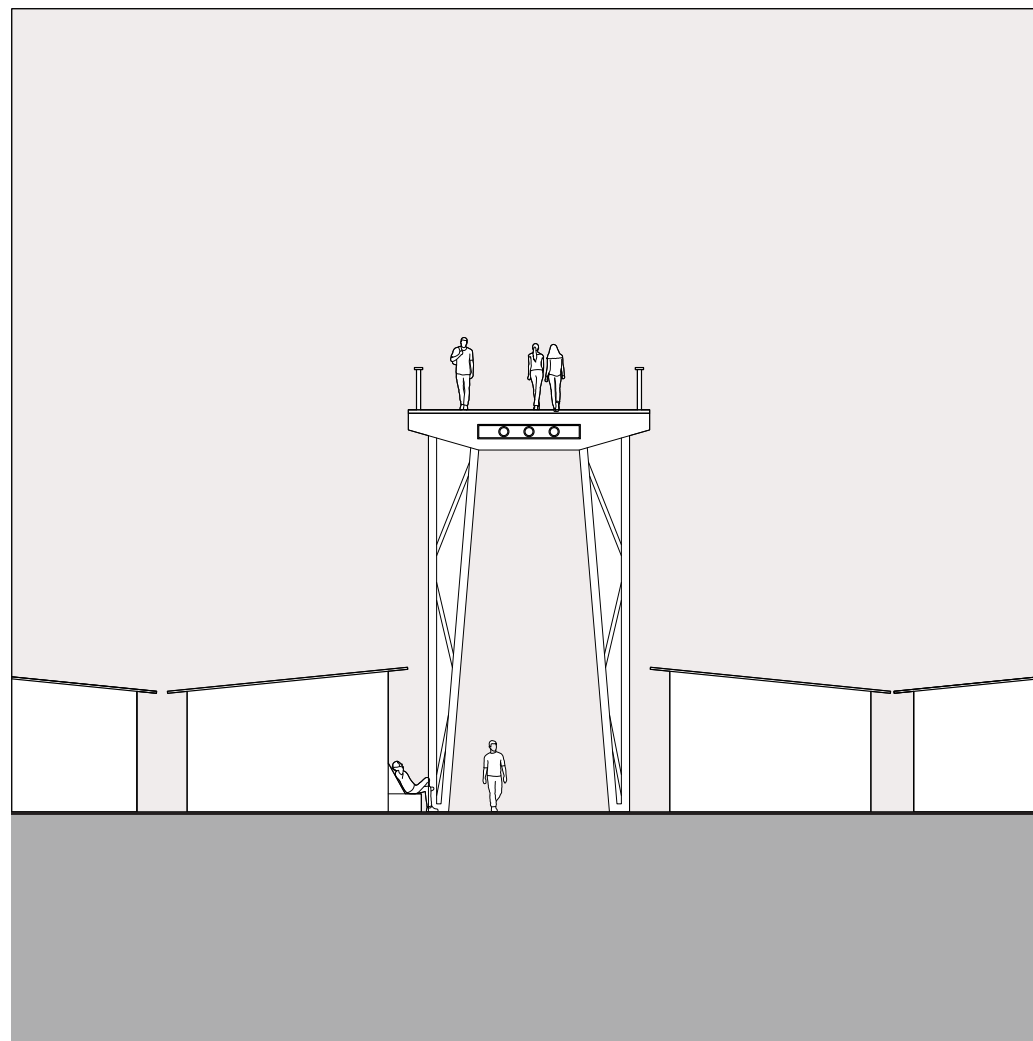

Connecting footbridges act as utility conduits.



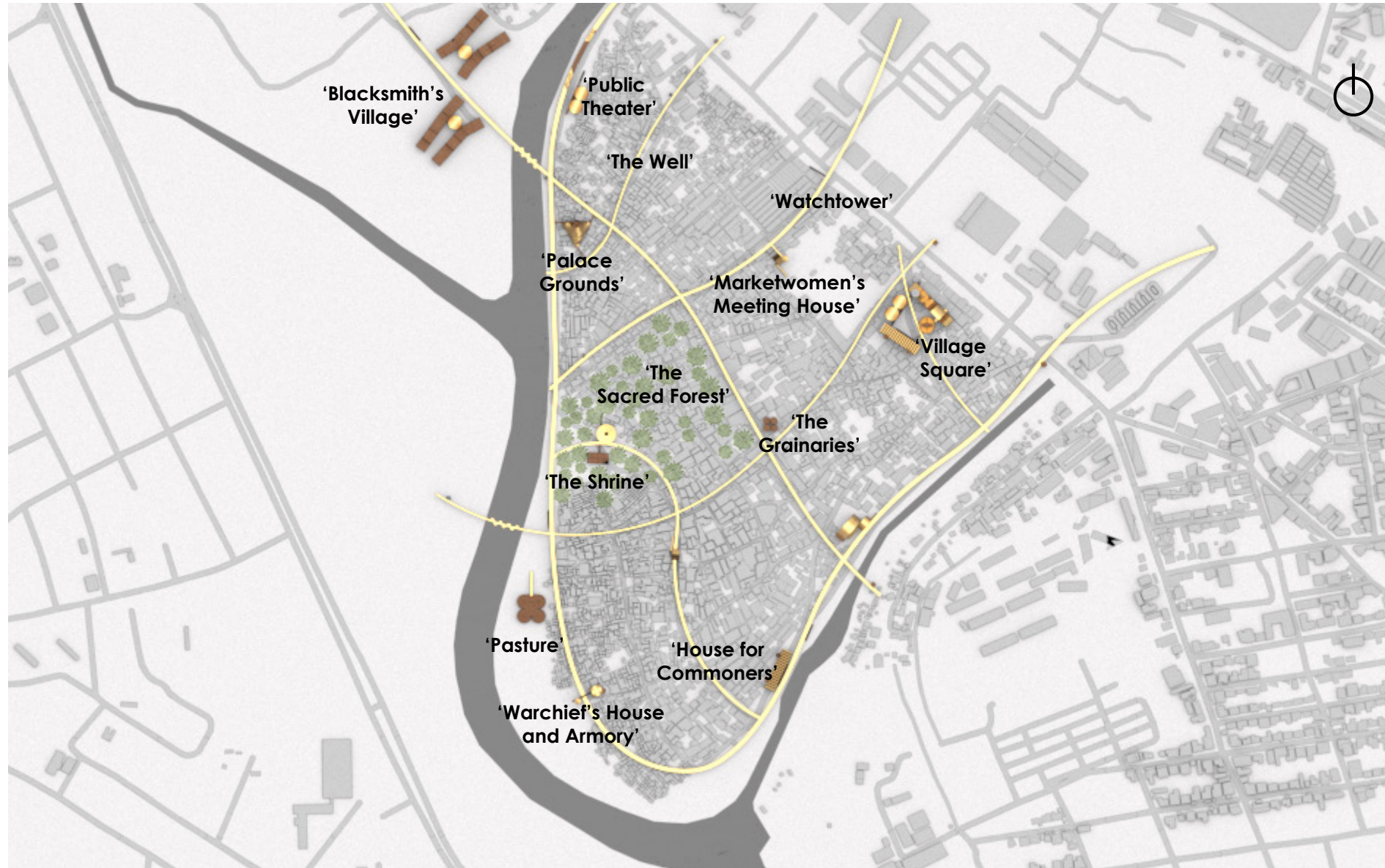



African Architecture should learn to grapple with the continent on its own terms. Where it is told to simply satisfy needs, it must instead insist on daring to dream.

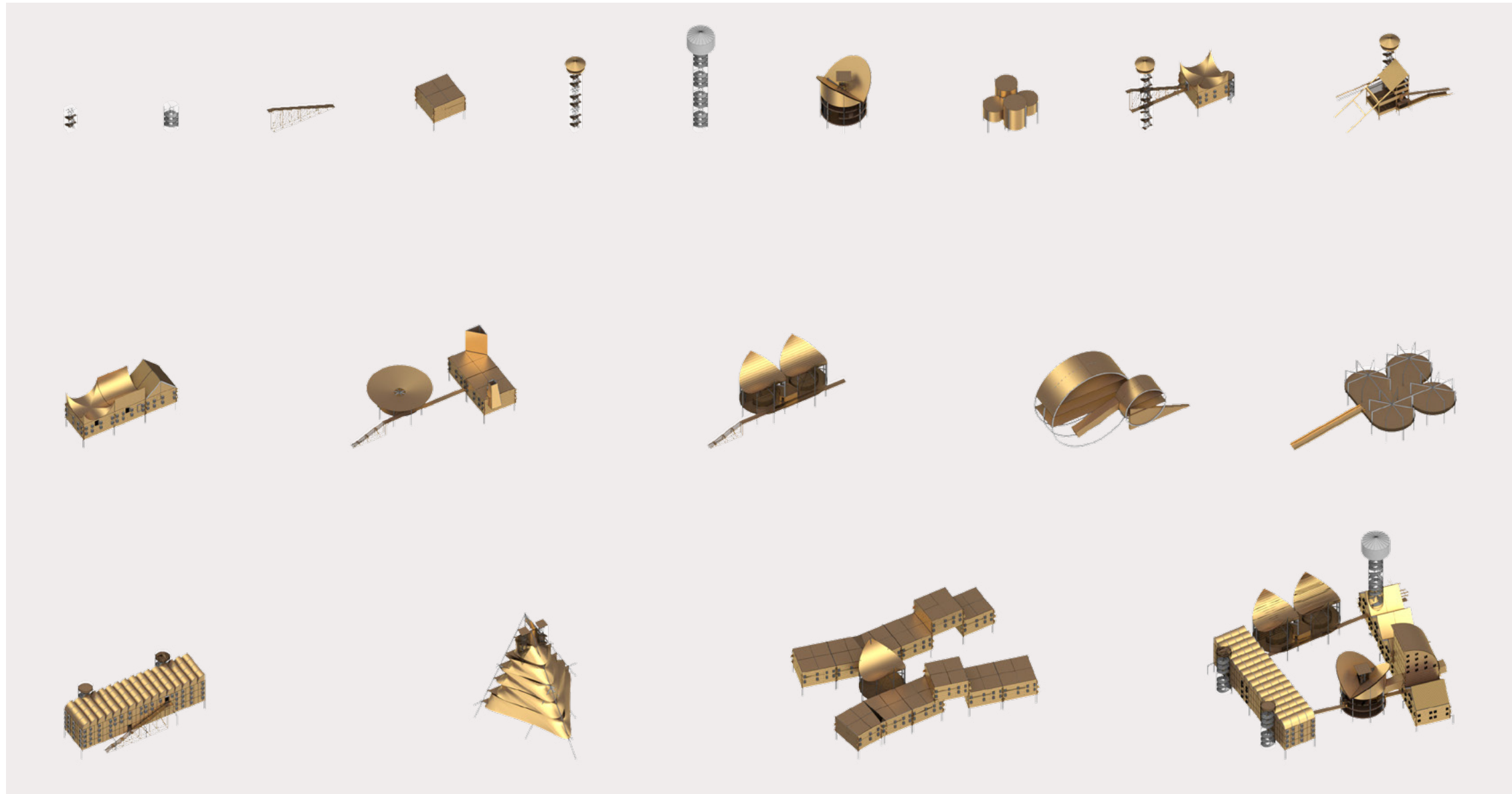

From Folly to Urbanism

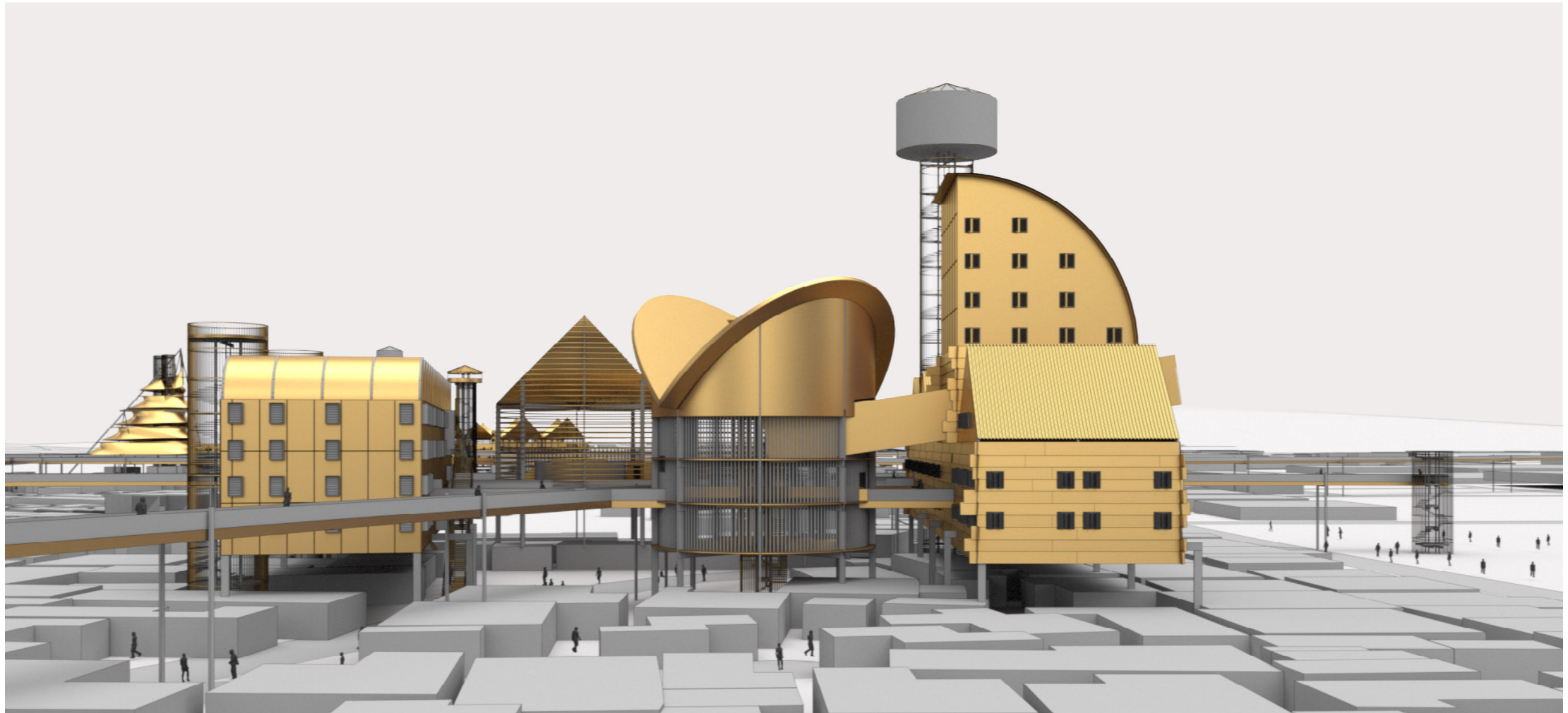

'The Village Square'

